

FIXTURE SUPPORTS

FIG. 0548 RESIDENTIAL FIXTURE SUPPORTS FOR SIPHON JET WATER CLOSETS ADAPTER TYPE WITHOUT FITTINGS



FIXTURE SUPPORTS

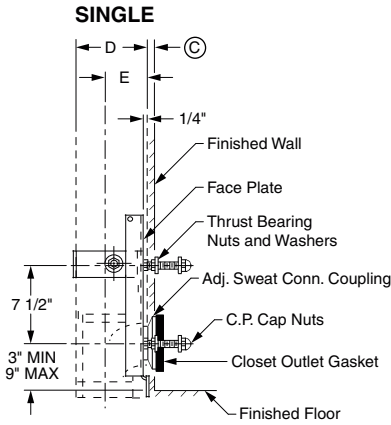
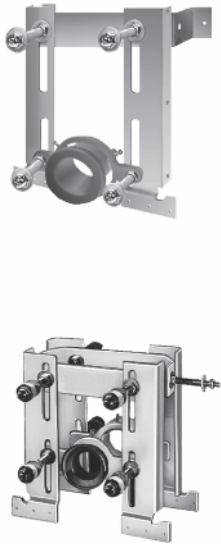

Fig. 0548
Side View

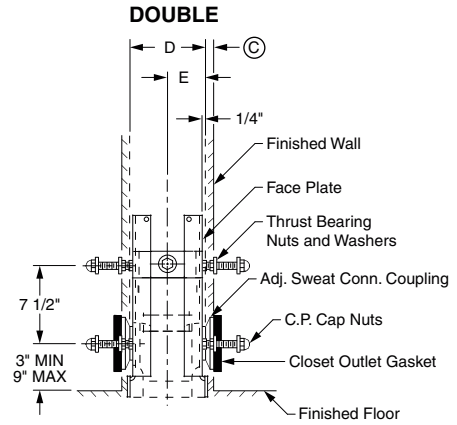

Fig. 0548D
Side View

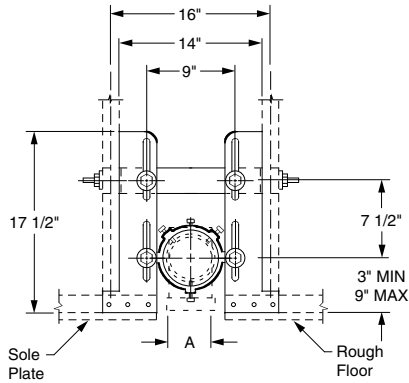

Fig. 0548
Front View

NOTE: Coupling should extend 5/16" beyond finished wall.

NOTE: Longer closet studs and couplings available when required.

© 1/2" MIN to 1 1/4" MAX regularly furnished.

OUTLET TYPE	FIGURE NO.	TYPE OF FITTING	STUD MOUNT	A SIZE	D STUD	E	APPROX. WT. LBS.
CAULK	0548-3	Single-3" Copper Sweat Connection	669.00	03"	2 x 6"	4"	17
	0548-4	Single-4" Copper Sweat Connection	891.00	04"	2 x 8"	5"	19
	0548D3	Double-3" Copper Sweat Connection	1,309.00	03"	2 x 8"	-	34
	0548P	Single-3" Plastic Connection	669.00	03"	2 x 8"	4 1/2"	18
	0548DP	Double-3" Plastic Connection	1,309.00	03"	2 x 10"	-	34

NOTE: Always specify fixture manufacturer's model name and number.

FIXTURE SUPPORTS

FIG. 0548F RESIDENTIAL SUPPORTS FOR SIPHON JET WATER CLOSETS ADAPTER TYPE WITHOUT FITTINGS



CUSTOMER DRIVEN SINCE 1926

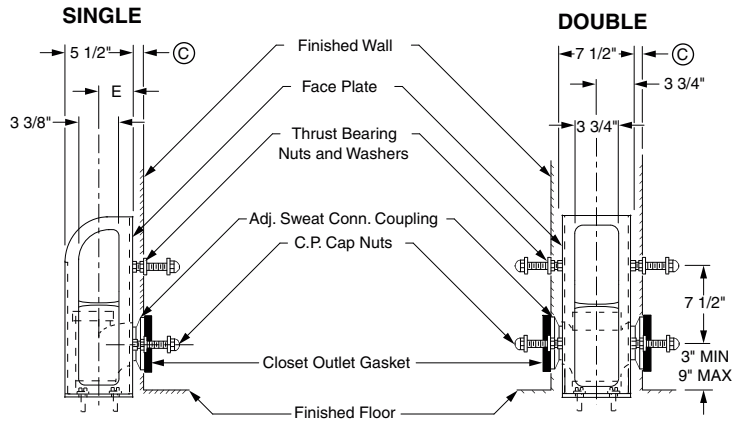

Fig. 0548F
Side View

Fig. 0548FD
Side View

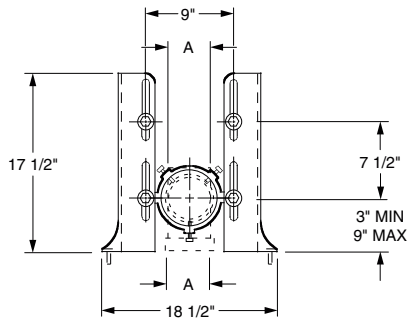

Fig. 0548F
Front View

NOTE: Coupling should extend 5/16" beyond finished wall.

NOTE: Longer closet studs and couplings available when required.

© 1/2" MIN to 1 1/4" MAX regularly furnished.

▲NOTE: Back of fitting extends beyond frame 1/2" for 4" sizes. Recommend use with 2 x 8 studs only.

OUTLET TYPE	FIGURE NO.	TYPE OF FITTING	FLOOR MOUNT*	A SIZE	E	APPROX. WT. LBS.
CAULK	0548F-3	Single-3" Copper Sweat Connection	1,026.00	03"	4"	38
	▲ 0548F-4	Single-4" Copper Sweat Connection	1,241.00	04"	5"	38
	0548FD3	Double-3" Copper Sweat Connection	1,662.00	03"	-	52
	0548FP	Single-3" Plastic Connection	1,026.00	03"	4 1/2"	37
	0548FDP	Double-3" Plastic Connection	1,662.00	03"	-	51

* Floor mount series may also be used in commercial applications where applicable.

NOTE: Always specify fixture manufacturer's model name and number.