

# Rainwater Harvesting – Catch it

*The word “sustainable” was undefined 20 years ago, a political topic 10 years ago and part of our culture today.*

By Peter Kraut

With LEED 3.0, water conservation is now a prerequisite and the use of rainwater harvesting can add up to 8 points to your scorecard. Still, these systems are not yet listed in any major code, nor are they defined in any adopted standard. As of today, the authority to prevent or permit these systems lies in our local jurisdictions. More importantly, the design and inspection of these systems is dependant on local knowledge.

Happily for everyone, there has been some recent progress on the issue. In October of 2009, The American Rainwater Catchment Systems Association (ARCSA) published a draft of a new standard titled Rainwater Catchment Design and Installation Standards. On February 1, 2010, the International Association of Plumbing and Mechanical Officials (IAPMO) published the 2010 Green Plumbing and Mechanical Supplement. This all came just in time, too. As I began the design of a new parking structure, a local rainwater harvesting ordinance was revealed. It requires that all commercial development and site plans submitted after June 1, 2010 must include a rainwater harvesting plan. This ordinance requires that 50% of the landscape water budget must come from rainwater harvested on site. That’s no easy task when you consider that the location is Tucson, Arizona.

Why capture and reuse rainwater? There are many good reasons. Some are obvious while others may not be. Let’s take a look:

- **Save water:** Using captured rainwater saves water. Every gallon of rainwater reused is one less gallon that must come from our overtaxed wells and reservoirs.
- **Save Money:** Using captured rainwater reduces potable water use. This lowers utility costs.
- **Reduce pollution:** Rainwater washes surface pollution into our storm drains. In many cases, this polluted water ends up in our oceans.
- **Maintain existing infrastructure:** Many of our storm drains and water supplies have reached their capacity. Rainwater harvesting reduces the load allowing them to remain in service while supporting new growth.

In Tucson, they suggest that a water budget be developed first. The annual requirements of different types of plants, as shown in Table 1, indicate that even “very low water use” plants require a great deal of water. Still, let’s consider medium water use plants: The plants will require 2.9 feet of water per year so we must harvest 1.45 feet per year for irrigation. Assuming 7,500 square feet of landscaping, we will need 10,875 cubic feet of water. That’s

over 80,000 gallons per year

Table 1 – Plant water demand per year

Plant water demand category	Water use (ft. / sq.ft.)
very low water use	0.8
low water use	1.7
medium water use	2.9
high water use	4.2

Having decided to proceed with rainwater harvesting, our first step is to collect it. Water can be collected from any hard surface. Roofs and decks are good sources of rainwater for re-use. These areas should be clear of overhanging vegetation and airborne pollution. Drain strainers and gutter screens are useful for removing large debris. Some areas, such as parking decks can contain significant pollutants and should be avoided.

Having collected the water, our next step is to convey it to a central point where it can be treated, stored and distributed. This should be accomplished using an approved roof drain system. Listed drains and pipes in a conventional system are common. Occasionally, long distances need to be covered where little or no slope is available. In these instances, a siphonic roof drain system might be appropriate. The General Motors Assembly Plant in Lansing, Michigan used just such a system.

Before entering the tank, the captured water must be filtered. The term first flush refers to the initial rain that cleanses the surfaces. The majority of the pollutants will be washed down with the first flush and this water should be avoided. Any diverter used for this purpose should be self-draining between rainfall events. The water drained from this device should be piped to a disposal location that will not cause erosion. Consideration should be given to the pollutants in this water, and when taken to the storm drain, local ordinances for the treatment of surface runoff may apply.

Following a first flush diverter — before the tank — a debris screen is required. Vortex filters, like the cut away shown in Photo A, are preferred in lieu of debris screens

*Continued on page 42*

# Rainwater

Continued from page 40



Photo A. Vortex filter cut-away. (courtesy of J.R. Smith Manufacturing)

and often replace the first flush diverter, as well. These devices incorporate a fine filter in a housing that provides an unpressurized circular flow of water. This allows debris to fall out of suspension and be washed down an auxiliary drain while 90% of the clean water makes it to the collection point. If debris screens are used, they should be configured with maintenance in mind. Regardless of what system is used, care should be taken to ensure that the system does not trap water on the roof.

The rainwater harvesting tank, called a cistern, can be located above or below grade. Above grade tanks should be opaque, UV resistant, and, where possible, shielded from direct sunlight. Below grade tanks should be provided with manholes and ballasts appropriate to withstand any buoyant forces from surrounding groundwater. They should be located outside of the bearing footprint of any surrounding structures. Manholes should be located and elevated to prevent intrusion by unfiltered groundwater. These tanks will require several fabricated connections.

At least one inlet is required. Auxiliary inlets may be necessary. An overflow outlet and a vent are also required. Typically, the vent is extended above grade and the overflow is routed to the storm drain system. In some cases, it may discharge to grade. Keep in mind that regular overflow is necessary for a healthy tank; it carries the floating

*Continued on page 44*

# Rainwater

*Continued from page 42*

debris out. This flow will therefore have a much higher concentration of solids than any other. A trap in the overflow and a screen on the vent will keep insects and rodents out of the tank.

Some thought should go into the sizing of the tank, but first the roof area needs to be checked. Let's go back to our Tucson example. First, the plants require 2.9 feet of water each year, but the annual rainfall is only 1 foot per year. We must therefore harvest our water over a much greater area than we are distributing it. Second, some months are drier than others. Due to monsoons, the rainfall rates in Tucson are not what you might guess. Now look at Los Angeles. A greater annual rainfall is interrupted with three months of almost no rain at all in the summer. Information, such as that shown in Table 2 (see page 56), can be found at the National Weather Service Forecast Office of the National Oceanic and Atmospheric Administration. You can find it on line at [www.noaa.gov](http://www.noaa.gov).

Tucson uses the arbitrary decision that a tank is filled and emptied four times a year. I prefer a more calculated approach. To meet our 50% city requirement, we need to harvest 10,875 cubic feet of water each year. If we harvest 12.17 inches, or about 1 foot of rain over our 40,000 square foot roof, we'll have 40,000 cubic feet of water each year. Ten months out of the year, we will collect more than we use. In some cases, a day-by-day model of rain-

water in and out of the tank may be necessary.

Now we can turn our attentions to the tank size. Considering the daily local weather statistics from NOAA, we should consider about a three weeks of drought protection. Using  $\frac{3}{52}$  of the annual need of 10,875 cubic feet, we should store 627 cubic feet, or just under 5,000 gallons. In places where rain is more frequent, smaller tanks can be used. In areas like Los Angeles, where several months without rain is common, bigger tanks are required.

When water enters the tank, care should be taken to avoid stirring the debris that has settled on the bottom. The inlet should be extended down, near the bottom of the tank and a smoothing inlet fitting should be used to direct the water upwards. Similarly, the water should be drawn off the tank from where it is cleanest — a few inches below the surface. A floating filter allows this to be done with ease while the water level in the tank fluctuates. To extract the water, a pump is needed. The pump should be controlled with a pressure sensor that energizes when pressure drops. A pneumatic tank is required keep the pressure during periods of no flow.

One more thing is needed. Even with a three-week storage, we will likely run out of water during May or June. Uniform rainfall just doesn't happen in nature. A domestic

*Continued on page 56*

# Rainwater

Continued from page 44

water back-up is necessary. It can be connected downstream of the pump with a pressure regulator and a check

cost. Any use within the building would require additional steps to remove any remaining debris and

**Table 2 – Normal monthly rainfall statistics**

Month	Tuscon Rainfall (in. / month)	Los Angeles Rainfall (in. / month)
January	0.99	3.1
February	0.88	3.5
March	0.81	2.6
April	0.28	1.1
May	0.24	0.3
June	0.24	0.1
July	2.07	0
August	2.30	0.1
September	1.45	0.3
October	1.21	0.5
November	0.67	1.4
December	1.03	2.5
<b>TOTAL</b>	<b>12.17</b>	<b>15.5</b>

eliminate odors before use. Sediment filters and carbon filters are most common. The flushing of toilets is probably the greatest use for captured rainwater within a building. Washing laundry is another good application for rainwater. It is naturally soft water and this saves soap as well as water. Unfortunately, most administrative authorities have been slow to adopt this use due to health concerns.

In closing, some interesting points *against* rainwater harvesting must be made. Who would oppose such a environmentally sound and sustainable practice? Well, until 2009, the State of Colorado prohibited rainwater harvesting and now allows it only for residential use subject to limitations. The reason is linked

valve, or simply used to fill the tank and controlled by a float. Since our harvested water is non-potable, a reduced pressure principle backflow device is required on the connection. Our completed system looks like figure 1.

What else can we do with the water once captured? Irrigation is the most likely due to the relatively low first

to the water rights of the people downstream. Capturing rainwater prevents it from reaching what would have been its ultimate destination. In a strange way, this makes sense. In Los Angeles, where excess storm water is simply drained into the ocean along with all of its pollutants, rainwater harvesting makes a little more sense. ■

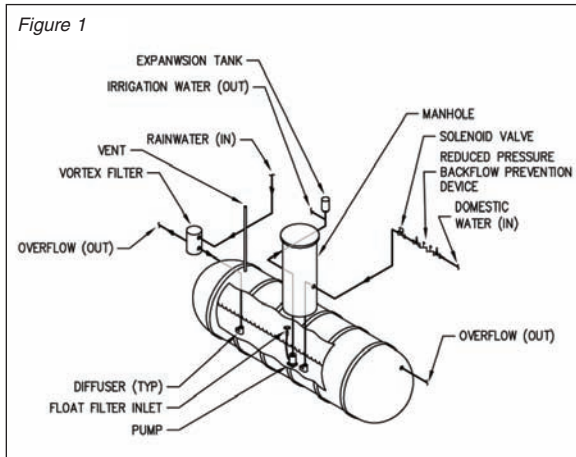

**Peter Kraut, P.E., CPD** is a licensed Mechanical Engineer in 22 states. He founded South Coast Engineering Group, near Los Angeles in 2001. In addition to conventional plumbing and HVAC projects, he has designed more than five million square feet of siphonic roof drainage systems in the United States. He can be reached by email at [pkraut@socoeng.com](mailto:pkraut@socoeng.com).