

B
 DRAWING NUMBER PM 2143
 SIZE A
 SCALE: NONE
 DATE: 8-31-07
 APPROVED BY: PJ
 CHECKED BY: PJ
 DRAWN BY: RN
 FIGURE NUMBER PM 2143

WE CAN ASSUME NO RESPONSIBILITY FOR USE OF SUPERSEDED OR VOID DATA

9660 STAINLESS STEEL TRENCH DRAIN INSTALLATION GUIDE

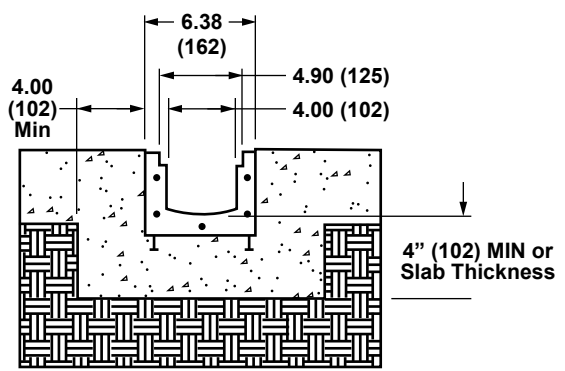

NOTE: Concrete around and under trench should be a minimum of 4" thick or the same thickness of the surrounding slab.

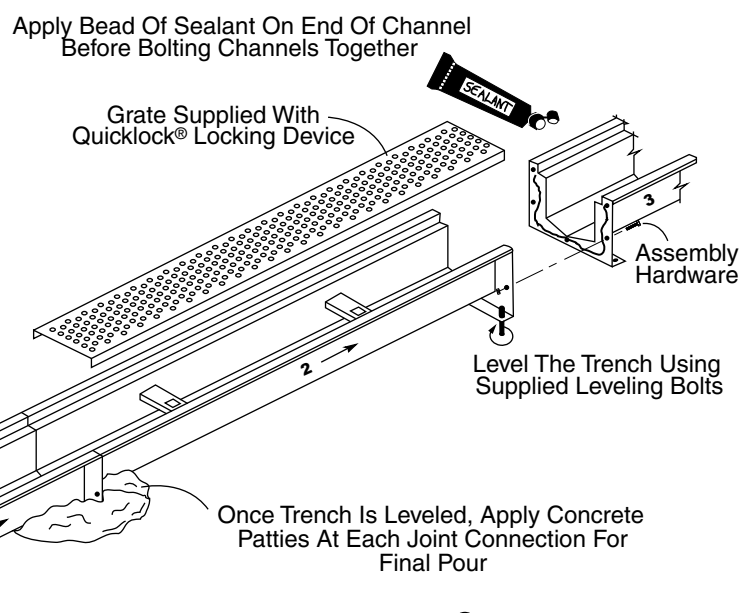

1. Assemble the 1 Meter Modular Sections as required. Apply a bead of the supplied Smith Seal Sealant on the end of the channel before bolting the channels together with the supplied hardware.
2. Use the leveling bolts to set the desired elevation.
3. Use a string line to ensure the run is straight and level.
4. Pour small patties of concrete around the leveling bolts to anchor the run.
5. When making the final pour, vibrate the concrete to remove air pockets. Ensure the entire channel is encased in concrete.
6. Slope concrete toward the trench and ensure that the finished level of concrete is 1/8" above lip of trench.

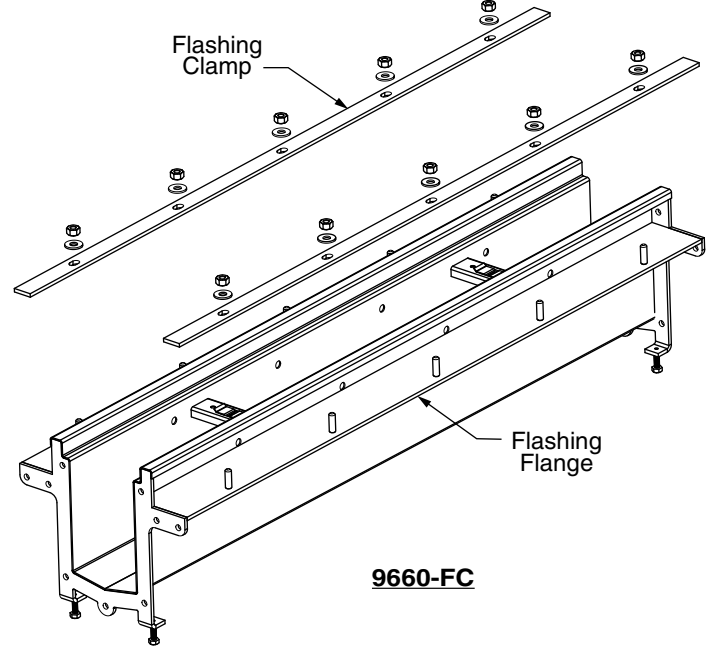

When Specified - FC (Flashing Clamp)

Install the 9660-FC trench drain following steps 1 thru 4. Then attach the membrane to the flashing flange on each side and ends and secure to the 9660 trench drain channel sections, using the flashing clamp and hardware provided. Then complete the final pour as required, see steps 5 and 6. **Note, these instructions are suggested only and may vary / differ based on job site conditions.**

NOTE: Dimensions shown in parentheses are in millimeters.

REV.	DATE	DESCRIPTION	BY	CKD. BY
B	03-26-10	Added Note & Changed Drawing	RN	PJ
A	11-28-07	Added Note & Changed Dim.	RN	MD

WEIGHT POUNDS	VOLUME CUBIC FEET	FIGURE NUMBER
		PM 2143