

FIGURE NUMBER	9870-479-MD	DRAWN BY: RN	CHECKED BY: PJ	APPROVED BY: PJ	DATE: 8-30-04	SCALE: NONE	SIZE A	DRAWING NUMBER a9870-479-MD	A
---------------	--------------------	-----------------	-------------------	--------------------	------------------	----------------	------------------	--------------------------------	----------

DIMENSIONS ARE SUBJECT TO MANUFACTURERS TOLERANCE AND CHANGE WITHOUT NOTICE

WE CAN ASSUME NO RESPONSIBILITY FOR USE OF SUPERSEDED OR VOID DATA

9870-479-MD DUCTILE IRON MOSAIC PATTERN HEAVY DUTY GRATE

Heavy Duty, DIN 19580 Class C -56,000 lbs - 1,162 psi
For commercial pneumatic tire traffic patterns, forklifts and tractor trailers

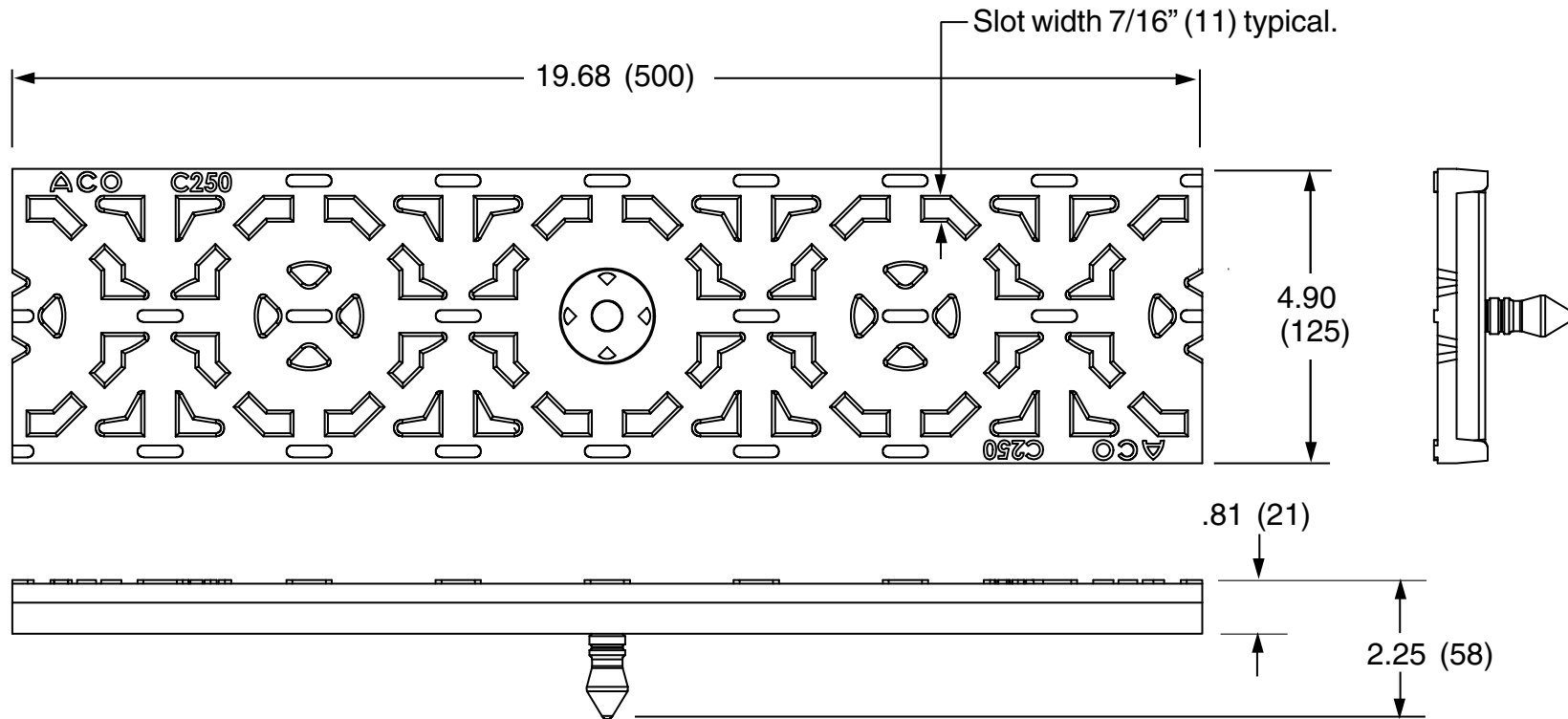

REGULARLY FURNISHED:
 Black Duco coated 1/2 Meter
 Ductile Iron Grate with Mosaic
 Pattern and Quicklock Locking
 Device.

OPEN AREA
 19.50 SQ IN

NOTE: Dimensions in
 parentheses are Metric.

SMITH® JAY R. SMITH MFG. CO.®
 DIVISION OF SMITH INDUSTRIES, INC.
 POST OFFICE BOX 3237
 MONTGOMERY, ALABAMA 36109-0237 (USA)
 TEL: 334-277-8520 FAX: 334-272-7396 www.jrsmith.com





MEMBER OF:

A	1-15-10	Added Dim. Note	RN	PJ
REV.	DATE	DESCRIPTION	BY	CKD.BY