



JAY R. SMITH MFG. CO.
 DIVISION OF SMITH INDUSTRIES, INC.
 POST OFFICE BOX 3237
 MONTGOMERY, ALABAMA 36109-0237 (USA)
 TEL: 334-277-8520 FAX: 334-272-7396 www.jrsmith.com



LOCATION

C
 DRAWING NUMBER: **SSQ-9-2039**
 SIZE: **A**
 SCALE: **NONE**
 DATE: **03-07-05**
 APPROVED BY: **JM**
 CHECKED BY: **JM**
 DRAWN BY: **JJ**
SQ-9-2039
 FIGURE NUMBER

WE CAN ASSUME NO RESPONSIBILITY FOR USE OF SUPERSEDED OR VOID DATA
 DIMENSIONS ARE SUBJECT TO MANUFACTURERS TOLERANCE AND CHANGE WITHOUT NOTICE

SPECIAL PURPOSE DOWNSPOUT COVER

WITH HINGED PERFORATED COVER

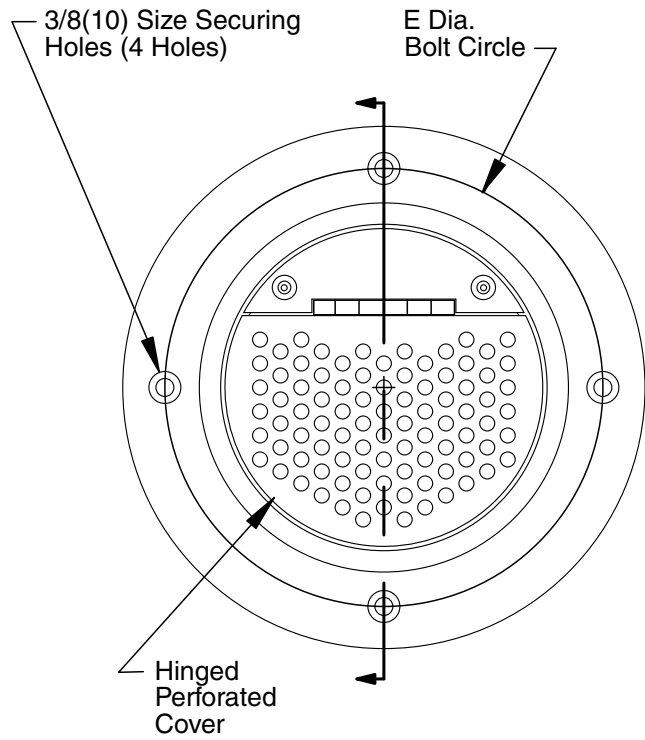

FRONT VIEW

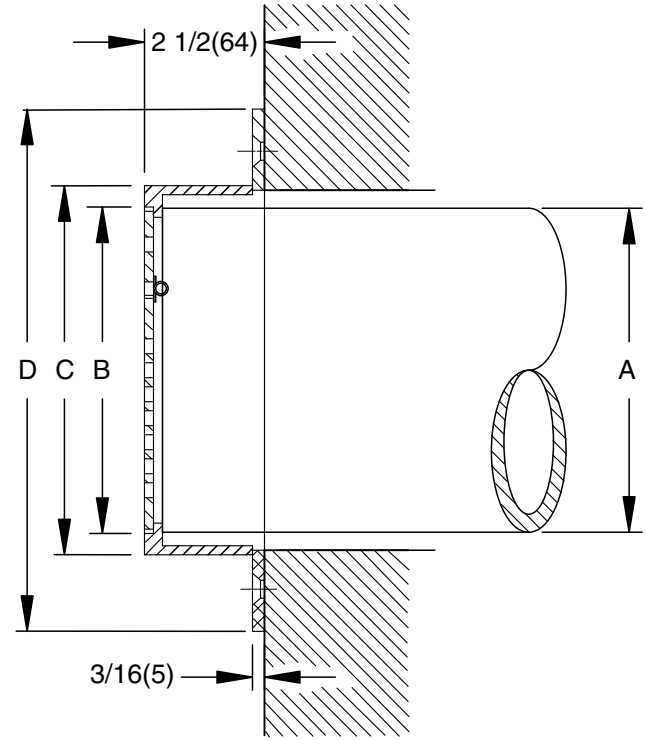

RIGHT SIDE SECTION VIEW

A (Pipe Size)	B DIA.	C DIA.	D DIA.	E DIA.
0150(38)	3 1/2(89)	4 1/2(115)	7 11/16(194)	6(150)
02(50)	3 1/2(89)	4 1/2(115)	7 11/16(194)	6(150)
03(75)	3 1/2(89)	4 1/2(115)	7 11/16(194)	6(150)
04(100)	4 9/16(116)	5 9/16(142)	8 3/4(220)	7 1/8(181)
05(125)	5 5/8(143)	6 5/8(168)	9 13/16(251)	8 1/4(210)
06(150)	6 11/16(169)	7 11/16(194)	10 7/8(278)	9(230)
08(200)	8 11/16(219)	9 11/16(249)	12 7/8(328)	11 1/4(285)
10(250)	10 13/16(276)	11 13/16(301)	15(380)	13 1/2(345)
12(305)	12 13/16(326)	13 13/16(351)	17(430)	15 1/2(395)
15(380)	16(405)	16 15/16(429)	20 1/8(513)	18 1/2(470)

Fig. SQ-9-2039.....DOWNSPOUT COVER

REGULARLY FURNISHED:
 Fabricated Type 304 Stainless Steel
 Downspout Cover with Hinged Perforated Cover.

VARIATIONS:
 Vandal Proof -U

OPTIONAL MATERIALS:
 Fabricated Polished Brass -PB
 Fabricated Chrome Plated Brass -CP

NOTE: Dimensions shown in parentheses are in millimeters.

REV.	DATE	DESCRIPTION	BY	CKD. BY	WEIGHT POUNDS	VOLUME CUBIC FEET	FIGURE NUMBER
C	6-16-08	Revised Cover	TBW	CL			SQ-9-2039
B	9-13-07	Revised Table	RN	CL			