

G

SMITH® JAY R. SMITH MFG. CO.
 DIVISION OF SMITH INDUSTRIES, INC.
 POST OFFICE BOX 3237
 MONTGOMERY, ALABAMA 36109-0237 (USA)
 TEL: 334-277-8520 FAX: 334-272-7396 www.jrsmith.com



LOCATION

DRAWING NUMBER
SSQ-9-1195

SIZE
A

SCALE:
NONE

DATE:
2-6-89

APPROVED BY:

CHECKED BY:

DRAWN BY:
CMB

SQ-9-1195

FIGURE NUMBER

WE CAN ASSUME NO RESPONSIBILITY FOR USE OF SUPERSEDED OR VOID DATA

KETTLE DRAIN

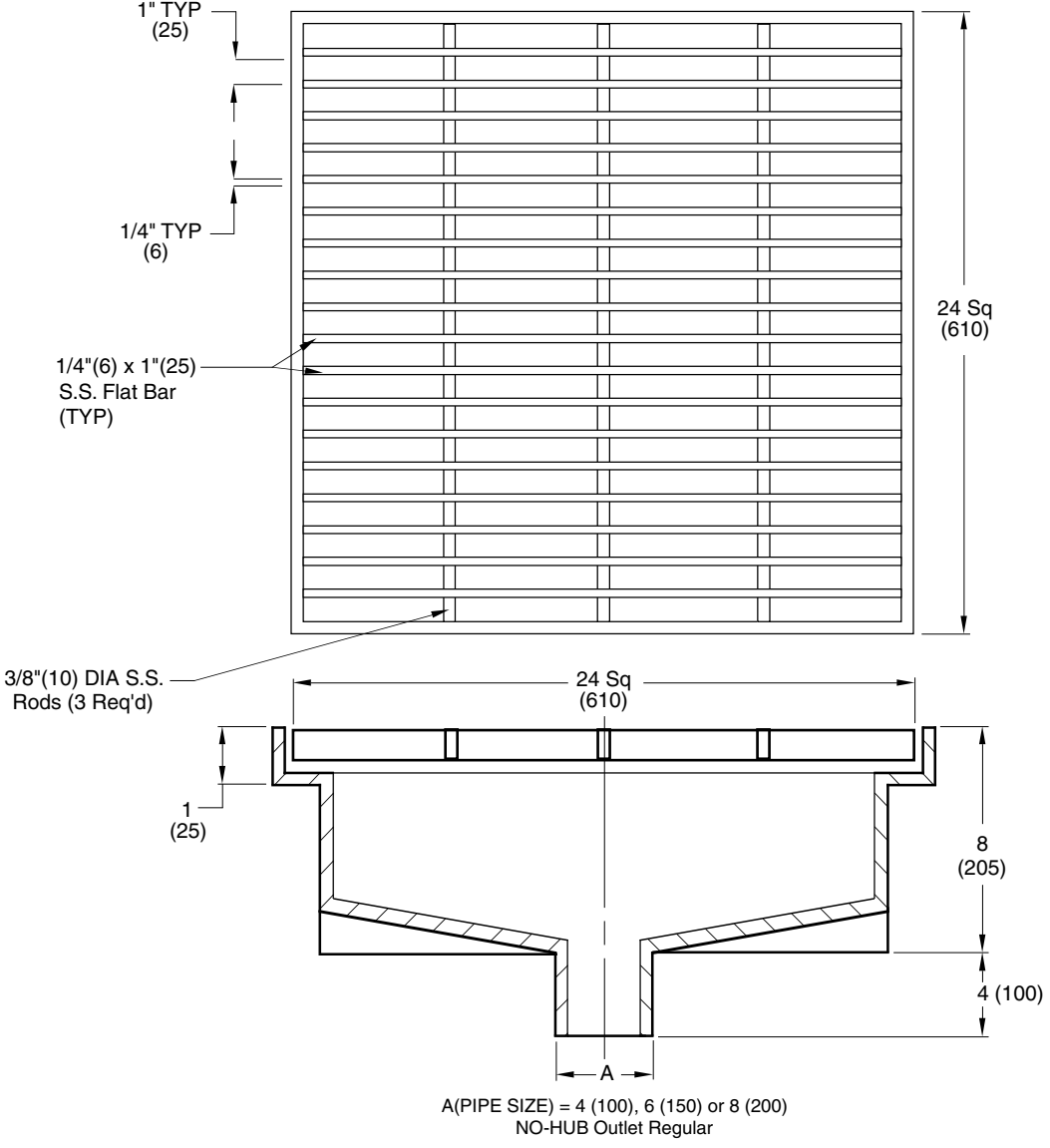

REGULARLY FURNISHED:
 Fabricated 304 Stainless Steel 14 Gauge Body with Stainless Steel Bar Grates. Top of Grate Provided with Satin Finish.

- VARIATIONS:**
- Dome Bottom Strainer (DBS)
 - Flat Bottom Strainer (FBS)
 - Stainless Steel Waste Cup (WC) in Drain Outlet
 - Anchor Flange (F)
 - Anchor Flange with Flashing Clamp (F-C)
 - Stainless Steel Perforated Bucket -B
 - Stainless Steel Mesh Lined Bucket -B/M

OPTIONAL MATERIALS:
 Fabricated from 316 Stainless Steel

Note: Dimensions shown in parentheses are in millimeters.

G	11-21-03	Rev. Reg. Furn. & Vari. (WO-3117)	RN	CR
F	12/02/02	Added -H-B to Figure Number	RN	
E	12/21/00	Added Millimeters	RN	McD.
D	3-16-99	Rev. Dwg., Regularly Furnished	CMB	
C	11/91	Rev. Variations	CMB	
B	7/91	Rev. Variations	CMB	
REV.	DATE	DESCRIPTION	BY	CKD. BY

WEIGHT POUNDS	VOLUME CUBIC FEET

FIGURE NUMBER
SQ-9-1195