



**JAY R. SMITH MFG. CO.**  
 DIVISION OF SMITH INDUSTRIES, INC.  
 POST OFFICE BOX 3237  
 MONTGOMERY, ALABAMA 36109-0237 (USA)  
 TEL: 334-277-8520 FAX: 334-272-7396 www.jrsmith.com



LOCATION

# PLANTING AREA DRAINS

C DRAWING NUMBER s1909  
 SIZE A  
 SCALE: NONE  
 DATE: 5-7-08  
 APPROVED BY: CL  
 CHECKED BY: CL  
 DRAWN BY: RN  
 1909  
 FIGURE NUMBER

WE CAN ASSUME NO RESPONSIBILITY FOR USE OF SUPERSEDED OR VOID DATA  
 DIMENSIONS ARE SUBJECT TO MANUFACTURERS TOLERANCE AND CHANGE WITHOUT NOTICE

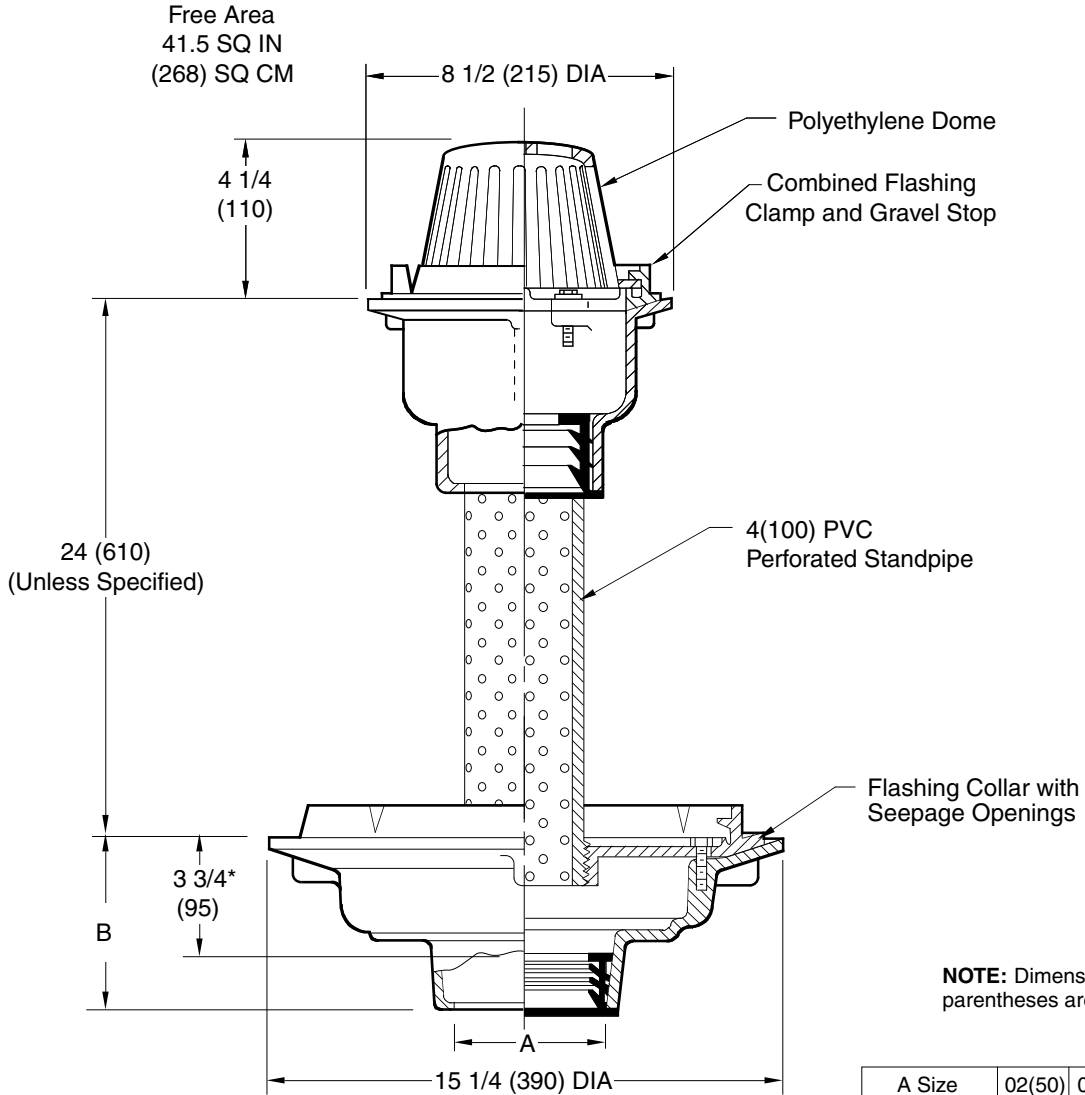

**NOTE:** Dimensions shown in parentheses are in millimeters.

\* This Dimension to Internal Stop of Speedi-Set Gasket.

Fig. 1909C . . . . . CAULK OUTLET  
 Fig. 1909Y . . . . . NO-HUB OUTLET

A Size	02(50)	03(75)	04(100)
B	5(125) for Caulk, No-Hub and Speedi-Set 3 3/4(95) for Threaded		

**REGULARLY FURNISHED:**  
 Duco Cast Iron Lower Body and Flashing Collar with 4(100) PVC Perforated Standpipe and Duco Cast Iron Upper Body with Combined Flashing Clamp and Gravel Stop with Polyethylene Dome.

**VARIATIONS:**  
 L Speedi-Set Service Weight  
 LXH Speedi-Set Extra Heavy  
 Solid Standpipe -SP  
 Standpipe Covered with Stainless Steel Mesh -SSM

**OPTIONAL MATERIALS:**  
 Aluminum Dome -AD  
 Cast Iron Dome -CID  
 Galvanized Cast Iron Body & Collar -G  
 Galvanized Cast Iron Dome -CIDG  
 Rough Bronze Dome -PB

REV.	DATE	DESCRIPTION	BY	CKD. BY
C	04/19/10	Added 24 unless specified	JJ	TK
B	03/25/10	Removed SQ note	JJ	TK
A	10/30/09	Renamed as 1909	JJ	TK

WEIGHT POUNDS	VOLUME CUBIC FEET

**FIGURE NUMBER**  
**1909**