

DOWNSPOUT BOOTS

FUNCTION: Used as a transition piece for connecting sheet metal exposed downspout to underground cast iron soil piping. Sturdy cast iron construction provides the necessary protection of the lower part of the exposed downspout from damage.

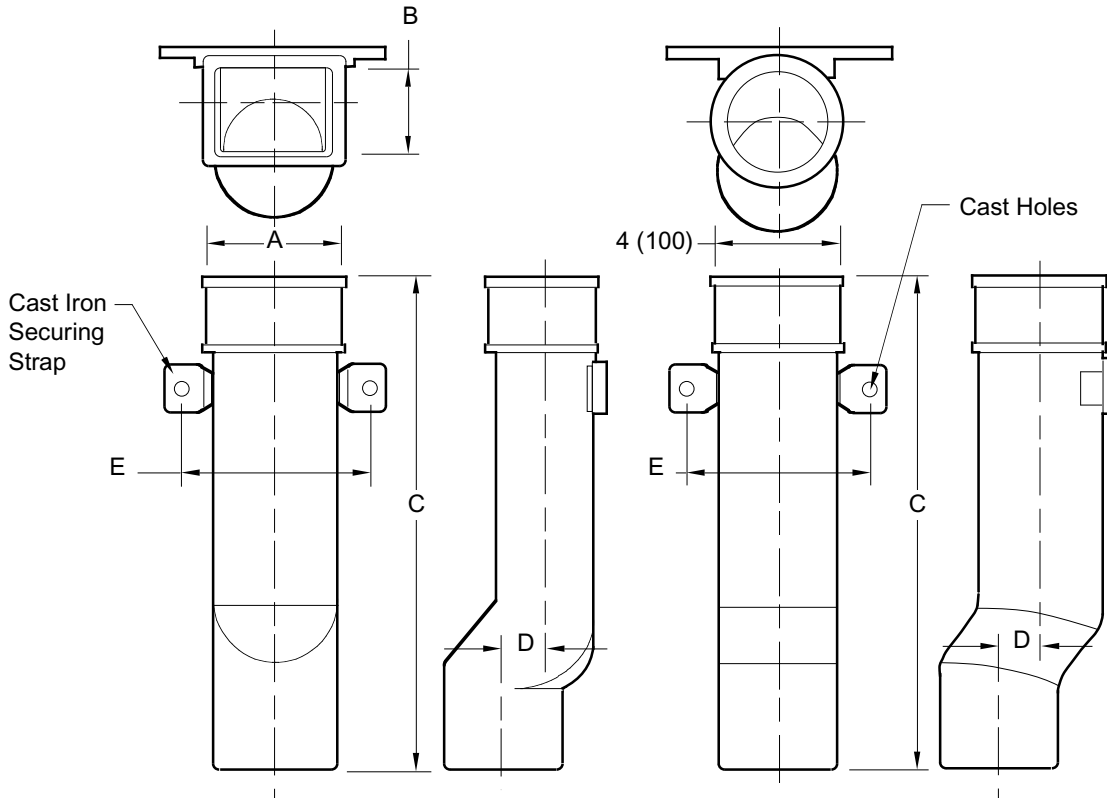

Fig. 1785 Series ... 4(100) x 3"(76) RECTANGULAR
 Fig. 1786 Series ... 5(125) x 4"(100) RECTANGULAR

Fig. 1787 Series ... 4"(100) ROUND

4(100) x 3"(76) SIZE			
Figure No.	C Length	D	E
1785-12	12(305)		
1785-18	18(455)	1 1/2 (38)	6 5/8 (168)
1785-24	24(610)		

5(125) x 4"(100) SIZE			
Figure No.	C Length	D	E
1786-24	24(610)	1(25)	7 5/8(194)

4"(100) ROUND SIZE			
Figure No.	C Length	D	E
1787-18	18(455)	1(25)	6 1/8(155)

NOTE: All downspout boots have 4"(100) spigot end for connection with 4"(100) pipe.

REGULARLY FURNISHED:
 Cast Iron Body and Strap with 5/16"(8) Dia. Cast Holes for Flat Head Bolts, Typical. All Shapes Unpainted.

NOTE: Dimensions shown in parentheses are in millimeters.

DRAWING NUMBER: S1785
 SIZE: A
 SCALE: NONE
 DATE: 5-24-85
 APPROVED BY: TD
 CHECKED BY: TD
 DRAWN BY: PL
 FIGURE NUMBER: 1785, 1786, 1787
 DIMENSIONS ARE SUBJECT TO MANUFACTURERS TOLERANCE AND CHANGE WITHOUT NOTICE
 WE CAN ASSUME NO RESPONSIBILITY FOR USE OF SUPERSEDED OR VOID DATA

REV.	DATE	DESCRIPTION	BY	CKD. BY	WEIGHT POUNDS	VOLUME CUBIC FEET	FIGURE NUMBER
B	4-7-97	Added Millimeters					1785, 1786, 1787
A	7-7-94	Submittal Update	EMB	BS			