

ROOF ACCESSORY

THREADED TYPE ROOF COUPLING

FUNCTION: Used as a counterflashing sleeve where the roofing membranes are terminated at the stack which passes through the roof. Sleeve is threaded so that stack may be extended to the desired height.

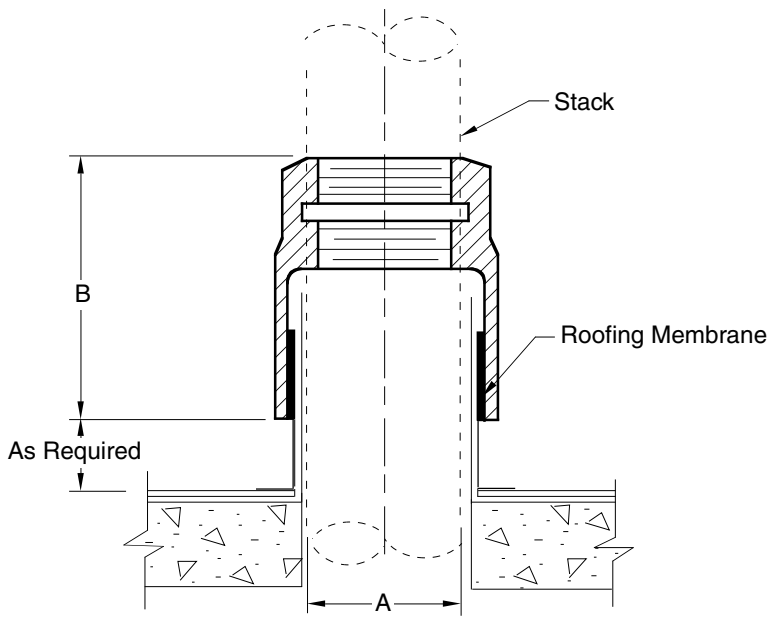

Fig. 1750T

NOTE: Dimensions shown in parentheses are in millimeters.

A	0125	0150	02	0250	03	04	05	06	08	10
SIZE	(30)	(40)	(50)	(65)	(75)	(100)	(125)	(150)	(200)	(255)
B	5	4	4	4 3/4	4 1/2	4 1/2	5 1/2	5 1/2	6 1/2	6 1/2
	(125)	(100)	(100)	(120)	(115)	(115)	(140)	(140)	(165)	165)

REGULARLY FURNISHED:
Duco Cast Iron

OPTIONAL MATERIALS:
 Galvanized Cast Iron -G

1750

FIGURE NUMBER	C	6-16-99	Revised Millimeters	CMD	BS	WEIGHT	VOLUME	FIGURE NUMBER
	B	4-7-97	Added Millimeters	EMB	BS	POUNDS	CUBIC FEET	1750
	A	7-1-94	Submittal Update	EMB	BS			
REV.	DATE	DESCRIPTION	BY	CKD. BY				

DIMENSIONS ARE SUBJECT TO MANUFACTURERS TOLERANCE AND CHANGE WITHOUT NOTICE

DRAWING NUMBER
S1750

SCALE:
NONE

DATE:
5-24-85

APPROVED BY:
TD

CHECKED BY:
TD

DRAWN BY:
VGD

SIZE
A

CUSTOMER
DRIVEN

WE CAN ASSUME NO RESPONSIBILITY FOR USE OF SUPERSEDED OR VOID DATA