

F



JAY R. SMITH MFG. CO.
 DIVISION OF SMITH INDUSTRIES, INC.
 POST OFFICE BOX 3237
 MONTGOMERY, ALABAMA 36109-0237 (USA)
 TEL: 334-277-8520 FAX: 334-272-7396 www.jrsmith.com



MEMBER OF:

LOCATION

SCUPPER DRAINS

FUNCTION: Used at specific angles of junction of roof and parapet with connection to outside conductor. Convex grate allows ample drainage area if sides become clogged with debris. Clamping arrangement insures watertight assembly.

DRAWING NUMBER
S1580

SIZE
A

SCALE:
NONE

DATE:
5-24-85

APPROVED BY:
TD

CHECKED BY:
TD

DRAWN BY:
RH

WE CAN ASSUME NO RESPONSIBILITY FOR USE OF SUPERSEDED OR VOID DATA

DIMENSIONS ARE SUBJECT TO MANUFACTURERS TOLERANCE AND CHANGE WITHOUT NOTICE

Free Area
111 SQ IN
(716) SQ CM

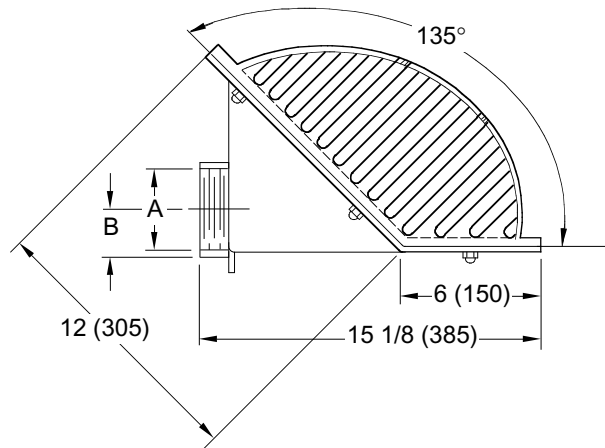
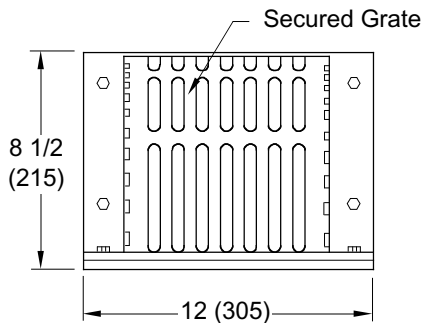

Fig. 1580T THREADED OUTLET

A SIZE	02 (50)	03 (75)	04 (100)	05 (125)	06 (150)
B	1 3/4 (44)	2 1/4 (57)	2 3/4 (70)	3 1/4 (83)	4 (100)

REGULARLY FURNISHED:
 Cold Galvanized Steel Body with Rough Bronze Grate and Flashing Clamp.

OPTIONAL MATERIALS:
 Nickel Bronze Top -NB
 Polished Bronze Top -PB

NOTE: Dimensions shown in parentheses are in millimeters.

1580

F	6-16-99	Revised Millimeters	CMD	BS
E	7-19-96	Added Millimeters	EMB	BS
D	6-30-94	Revised	EMB	BS
C	6-7-93	Submittal Update	EMB	BS
B	6-20-91	Rev. Reg. Furn.	EMB	JCS
REV.	DATE	DESCRIPTION	BY	CKD. BY

WEIGHT POUNDS	VOLUME CUBIC FEET

FIGURE NUMBER
1580