

# DEEP SUMP PROMENADE DECK DRAIN

**FUNCTION:** Used in roof systems where the insulated membrane assembly of waterproofing is provided. Used where built up felt and asphalt waterproofing is installed on a flat roof construction which is designed for parking decks or promenades for recreational purposes. Adjustable extension sleeve permits top adjustment.

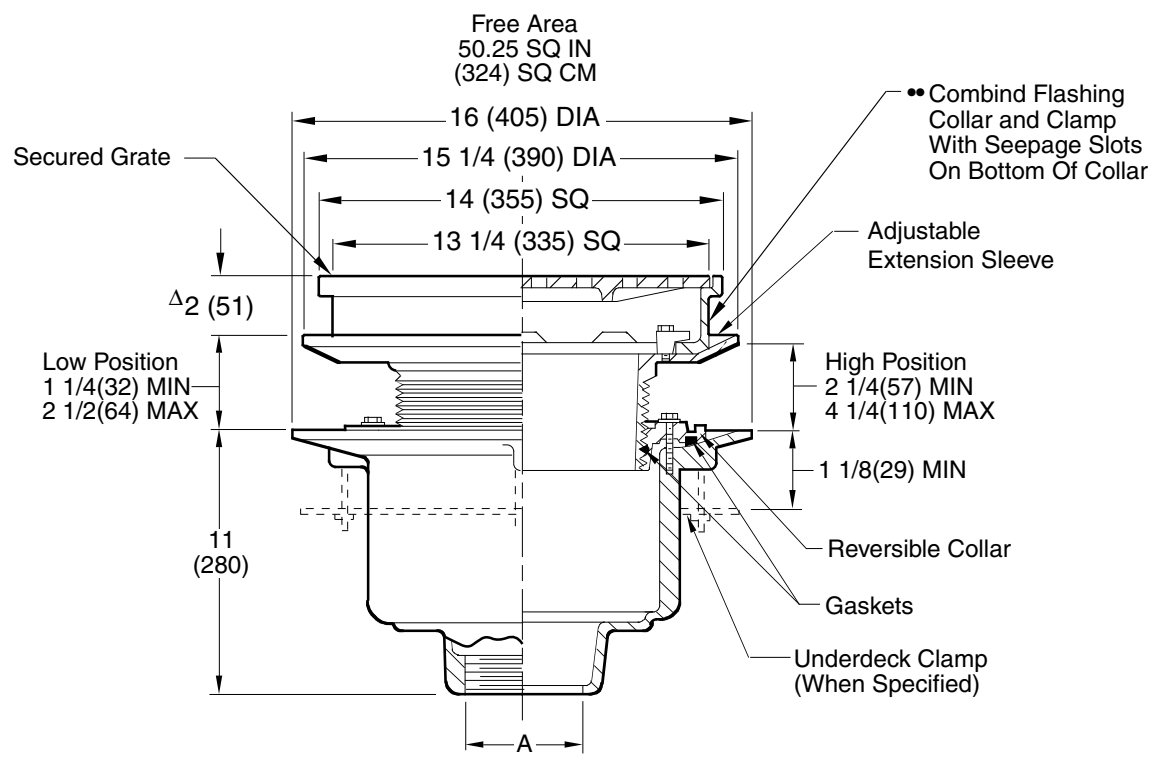

A (Pipe Size) = 02(50), 03(75), 04(100), 05(125) or 06(150)

recommended deck opening

with suffix -R	17 (430) DIA
less suffix -R	14 (355) DIA

XX	MIN	MAX
Low Position	1 1/4 (32)	2 1/2 (64)
High Position	2 1/4 (57)	4 1/4 (110)

**REGULARLY FURNISHED:**

Duco Cast Iron Body with Adjustable Extension Sleeve, Reversible Collar, Combined Flashing Collar and Clamp and Secured Square Hole Grate.

•• Specify Suffix -W for Applications Requiring "Loose-Set" Pavers.

Δ Add 1/8" (3) when bronze top is specified.

**VARIATIONS:**

- Bucket-B
- Expansion Joint (Specify Fig. 1710)
- "L" Shaped Underdeck Clamp -CL
- L Speedi-Set Service Weight 02(50), 03(75), 04"(100) sizes
- LXH Speedi-Set Extra Heavy 02(50), 03(75), 04"(100) sizes
- NO-HUB Adaptor (Specify Fig. 2646Y)
- Sump Receiver -R
- Underdeck Clamp -C
- Vandal Proof Grate -U
- T Threaded Outlet
- 3/8" (10) Dia. Holes - (8) Required -W

**OPTIONAL MATERIALS:**

- Ductile Iron Grate -M
- Galvanized Cast Iron -G
- Nickel Bronze Top -NB
- Polished Bronze Top -PB

**NOTE:** Dimensions shown in parentheses are in millimeters.

**NOTE:** Floor drains or area drains used to drain areas subject to rainfall should have an open area equal to twice the cross sectional area of the connecting pipe.

DRAWING NUMBER S1446  
 SIZE A  
 SCALE: NONE  
 DATE: 8-30-01  
 APPROVED BY: AM  
 CHECKED BY: CR  
 DRAWN BY: RN  
 1446  
 DIMENSIONS ARE SUBJECT TO MANUFACTURERS TOLERANCE AND CHANGE WITHOUT NOTICE  
 FIGURE NUMBER

REV.	DATE	DESCRIPTION	BY	CKD. BY
A	9-21-07	Rev. Variations	RN	AM

WEIGHT POUNDS	VOLUME CUBIC FEET

**FIGURE NUMBER**  
**1446**