

S



JAY R. SMITH MFG. CO.

DIVISION OF SMITH INDUSTRIES, INC. POST OFFICE BOX 3237 MONTGOMERY, ALABAMA 36109-0237 (USA) TEL: 334-277-8520 FAX: 334-272-7396 www.jrsmith.com



MEMBER OF:

LOCATION

PROMENADE DECK DRAINS

PROMENADE DECK DRAIN FOR SPECIAL ROOF APPLICATIONS

FUNCTION: Used in roof deck systems where the insulated membrane assembly method of waterproofing is provided. Used where built-up felt and asphalt waterproofing is installed on a flat roof construction which is designed for parking decks or promenades for recreational purposes.

Free Area
50.25 SQ IN
(324) SQ CM

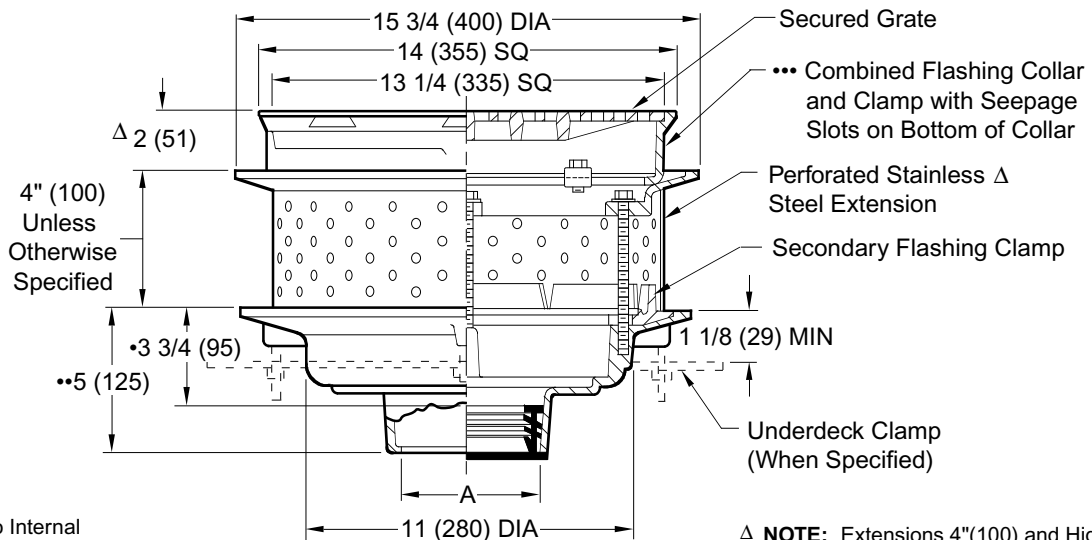

- This Dimension to Internal Stop of Speedi-Set Gasket.
 - Same for Caulk, NO-HUB and Speedi-Set. 3 3/4(95) for Threaded.
 - Specify Suffix -W for Applications Requiring "Loose-Set" Pavers.
- Δ Add 1/8 "(3) when bronze top is specified.

A (Pipe Size) = 02(50), 03(75), 04(100), 05(125) and 06(150)

- Fig. 1409C CAULK OUTLET
- Fig. 1409Y NO-HUB OUTLET

Δ **NOTE:** Extensions 4"(100) and Higher are Regularly Furnished Perforated Stainless Steel. Extensions Less Than 4"(100) are Regularly Furnished Cast Iron with 2 Rows of Seepage Holes.

recommended deck opening	
with suffix-R	17(430) DIA
less suffix-R	14(355) DIA

REGULARLY FURNISHED:

Duco Cast Iron Body, Perforated Stainless Steel Extension with Secondary Flashing Clamp, Cast Iron Top Frame and Heavy Duty Secured Grate.

VARIATIONS:

- Expansion Joint (Specify Fig. 1710)
- Extension -E (Specify Height)
- "L" Shaped Underdeck Clamp -CL
- L Speedi-Set Service Weight
02(50), 03(75) & 04"(100) sizes only
- LXH Speedi-Set Extra Heavy
02(50), 03(75) & 04"(100) sizes only
- Sump Receiver -R
- Underdeck Clamp -C
- Vandal Proof Grate -U
- T Threaded Outlet

OPTIONAL MATERIALS:

- Ductile Iron Grate -M
- Galvanized Cast Iron -G
- Nickel Bronze Top -NB
- Polished Bronze Top -PB

NOTE: Floor drains or area drains used to drain areas subject to rainfall should have an open area equal to twice the cross sectional area of the connecting pipe.

NOTE: Dimensions shown in parentheses are in millimeters.

DRAWING NUMBER
S1409

SIZE
A

SCALE:
NONE

DATE:
3-1-85

APPROVED BY:
TD

CHECKED BY:
TD

DRAWN BY:
WAS

FIGURE NUMBER
1409

WE CAN ASSUME NO RESPONSIBILITY FOR USE OF SUPERSEDED OR VOID DATA
DIMENSIONS ARE SUBJECT TO MANUFACTURERS TOLERANCE AND CHANGE WITHOUT NOTICE

S	12/11/03	Removed C2 Variation	JJ	BW
R	2/2/01	Rev. Opt. Mat.	RN	CL
Q	12/13/99	Submittal Update	JJ	BS
REV.	DATE	DESCRIPTION	BY	CKD. BY

WEIGHT POUNDS	VOLUME CUBIC FEET
------------------	----------------------

FIGURE NUMBER 1409
