

C



JAY R. SMITH MFG. CO.
 DIVISION OF SMITH INDUSTRIES, INC.
 POST OFFICE BOX 3237
 MONTGOMERY, ALABAMA 36109-0237 (USA)
 TEL: 334-277-8520 FAX: 334-272-7396 www.jrsmith.com



LOCATION

SPECIAL PURPOSE ROOF DRAIN

WATER DAM TYPE

FUNCTION: Used in flat roofs of any construction where a constant height of water is desired on the roof. It may also be used as an emergency overflow for conventional roofs, draining down rain water when the depth of the water on the roof reaches the water dam height.

Free Area
 102.5 SQ IN
 (661) SQ CM

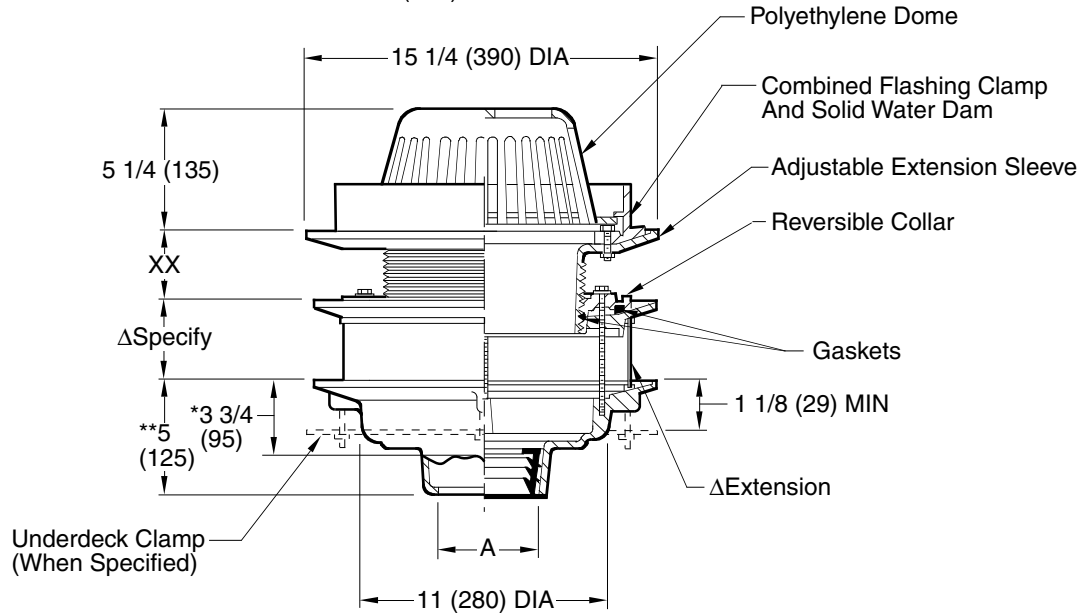

A (Pipe Size) = 02(50), 03(80), 04(100), 05(125), 06(150) or 08(200)

- Fig. 1045C (-E) CAULK OUTLET
- Fig. 1045Y (-E) NO-HUB OUTLET

XX	MIN	MAX
Low Position	1 1/4 (32)	2 1/2 (64)
High Position	2 1/4 (57)	4 (100)

*This dimension to internal stop of Speedi-Set Gasket

**Same for Caulk, NO-HUB and Speedi-Set, 3 3/4 (95) for Threaded

NOTE: Dimensions shown in parentheses are in millimeters.

recommended deck opening

with suffix -R	17 (430) DIA
less suffix -R	14 (355) DIA

ΔExt. thru 4" (100) size will be C.I., over 4" (100) will be fabricated stainless Steel. (Fab. SS ext. shown.)

REGULARLY FURNISHED:

Duco Cast Iron Body with Stainless Steel Fixed Extension and Adjustable Extension Sleeve, Reversible Collar, Combined Flashing Clamp and Water Dam and Polyethylene Dome

VARIATIONS:

- Expansion Joint (Specify Fig. 1710)
- "L" Shaped Underdeck Clamp -CL
- L Speedi-Set Service Weight 02(50), 03(80) & 04"(100) sizes only
- LXH Speedi-Set Extra Heavy 02(50), 03(80) & 04"(100) sizes only
- Removable Water Dam
- Secondary Flashing Clamp -C2
- Sump Receiver -R
- Underdeck Clamp -C
- With Seepage Holes -WSH
- T Threaded Outlet

OPTIONAL MATERIALS:

- Aluminum Dome -AD
- Cast Iron Dome -CID
- Galvanized Cast Iron -G
- Rough Bronze Dome -RBD

DRAWING NUMBER
S1045 (-E)

SIZE
A

SCALE:
NONE

DATE:
8-11-86

APPROVED BY:
SB

CHECKED BY:
JD

DRAWN BY:
CB

FIGURE NUMBER
1045 (-E)

WE CAN ASSUME NO RESPONSIBILITY FOR USE OF SUPERSEDED OR VOID DATA

DIMENSIONS ARE SUBJECT TO MANUFACTURERS TOLERANCE AND CHANGE WITHOUT NOTICE

REV.	DATE	DESCRIPTION	BY	CKD. BY
C	6-5-06	Revised Dim	TBW	AM
B	5-19-95	Submittal Update	EMB	BS
A	2-1-88	Rev. Note	CMB	CR

WEIGHT POUNDS	VOLUME CUBIC FEET
------------------	----------------------

FIGURE NUMBER
1045 (-E)