

SPECIAL PURPOSE ROOF DRAIN

WATER DAM TYPE

FUNCTION: Used in flat roofs of any construction where a constant height of water is desired on the roof. It may also be used as an emergency overflow for conventional roofs, draining down rain water when the depth of the water on the roof reaches the water dam height.

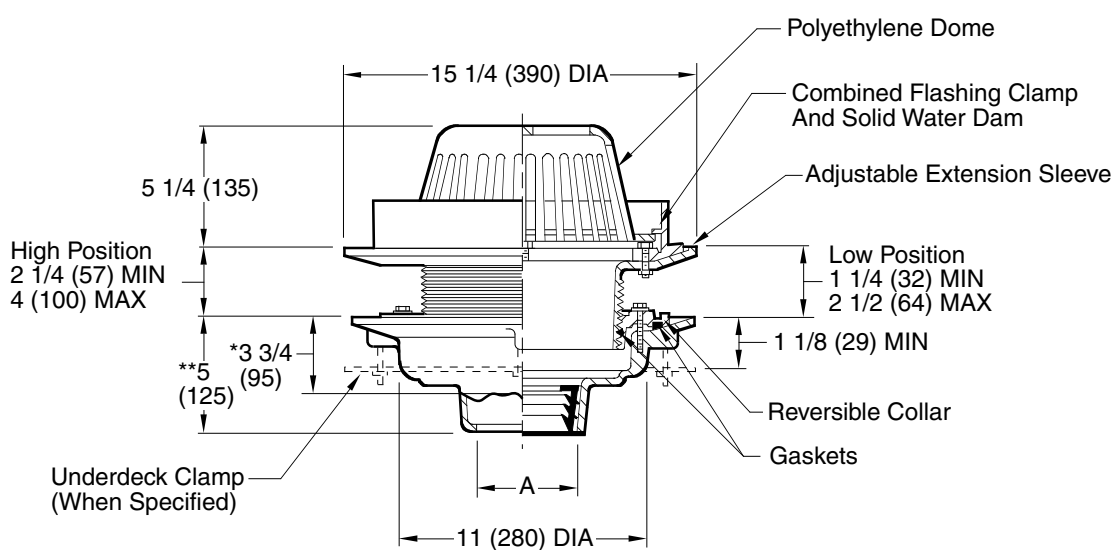

A (Pipe Size) = 02(50), 03(75), 04(100), 05(125), 06(150) or 08(200)

- Fig. 1045C CAULK OUTLET
- Fig. 1045Y NO-HUB OUTLET

*This dimension to internal stop of Speedi-Set Gasket
 **Same for Caulk, NO-HUB and Speedi-Set, 3 3/4 (95) for Threaded
NOTE: Dimensions shown in parentheses are in millimeters.

recommended deck opening	
with suffix -R	17 (430) DIA
less suffix -R	14 (355) DIA

REGULARLY FURNISHED:
 Duco Cast Iron Body with Adjustable Extension Sleeve, Reversible Collar, Combined Flashing Clamp and Water Dam and Polyethylene Dome.

- VARIATIONS:**
- 2 1/2(64), 3(76) or 4"(100) Water Dams Available -WD
 - Expansion Joint (Specify Fig. 1710)
 - "L" Shaped Underdeck Clamp -CL
 - L Speedi-Set Service Weight 02(50), 03(75) & 04"(100) sizes only
 - LXH Speedi-Set Extra Heavy 02(50), 03(75) & 04"(100) sizes only
 - Removable Water Dam
 - Secondary Flashing Clamp -C2
 - Sump Receiver -R
 - Underdeck Clamp -C
 - T Threaded Outlet

- OPTIONAL MATERIALS:**
- Aluminum Dome -AD
 - Cast Iron Dome -CID
 - Galvanized Cast Iron Body & Collar -G
 - Galvanized Cast Iron Dome -CIDG
 - Rough Bronze Dome -RBD

DRAWING NUMBER S1045
 SIZE A
 SCALE: NONE
 DATE: 4-8-86
 APPROVED BY: JMcD
 CHECKED BY: JD
 DRAWN BY: CMB
 FIGURE NUMBER 1045
 DIMENSIONS ARE SUBJECT TO MANUFACTURERS TOLERANCE AND CHANGE WITHOUT NOTICE
 WE CAN ASSUME NO RESPONSIBILITY FOR USE OF SUPERSEDED OR VOID DATA

D	6-5-06	Revised Dim.	TBW	AM			
C	5-26-99	Rev. Opt. Mat.	CMD	BS	WEIGHT	VOLUME	FIGURE NUMBER
B	5-18-95	Added Millimeters	EMB	BS	POUNDS	CUBIC FEET	1045
A	11-28-94	Submitted Update	CMB	BS			
REV.	DATE	DESCRIPTION	BY	CKD. BY			