



JAY R. SMITH MFG. CO.
 DIVISION OF SMITH INDUSTRIES, INC.
 POST OFFICE BOX 3237
 MONTGOMERY, ALABAMA 36109-0237 (USA)
 TEL: 334-277-8520 FAX: 334-272-7396 www.jrsmith.com



LOCATION

ROOF DRAINS

SPECIAL ROOF APPLICATIONS

FUNCTION: Used on roof systems where the insulated membrane assembly method of waterproofing is installed using a liquid membrane. The adjustable extension sleeve permits adjustment from a min of 1 1/4 (32) to a max of 4 (100) easily accommodating 2 3/4" (70) of varying insulation thicknesses. The positive threading allows smooth perimeter movement and circumferential support of the top at any adjusted elevation. A perforated stainless steel extension is supplied to retain the crushed gravel used in flat roof construction.

Free Area
 102.5 SQ IN
 (661) SQ CM

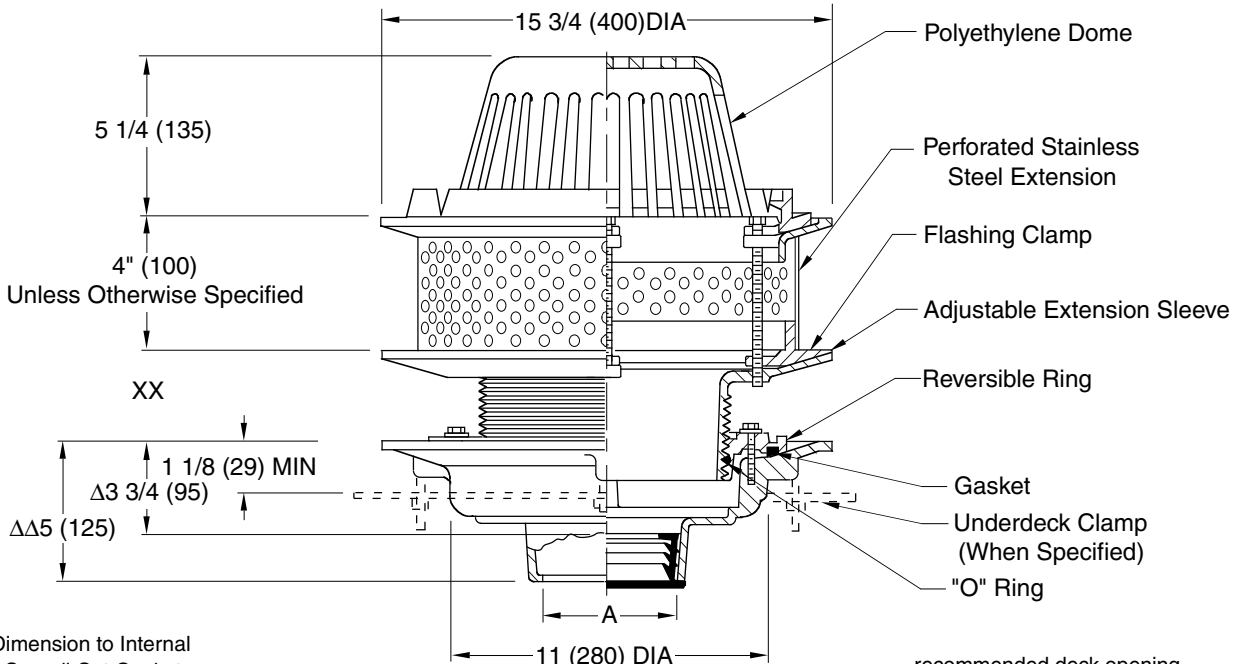

Δ This Dimension to Internal Stop of Speedi-Set Gasket.
 ΔΔ Same for caulk, NO-HUB and Speedi-Set, 3 3/4 (95) for Threaded.
NOTE: Dimensions shown in parentheses are in millimeters.

A (Pipe Size) = 02(50), 03(80), 04(100), 05(125) or 06(150)

recommended deck opening	
with suffix -R	17 (430) DIA
less suffix -R	14 (355) DIA

Fig. 1037C . . . CAULK OUTLET
 Fig. 1037Y . . . NO-HUB OUTLET

XX	MIN	MAX
Low Position	1 1/4 (32)	2 1/2 (64)
High Position	2 1/4 (57)	4 (100)

REGULARLY FURNISHED:

Duco Cast Iron Body with Adjustable Extension Sleeve, Perforated Stainless Steel Extension, Combined Flashing Clamp and Gravel Stop, and Polyethylene Dome

VARIATIONS:

- Expansion Joint (Specify Fig.1710) (Fig. 1010 only)
- Higher Gravel Stop (Specify Height) -HGS
- "L" Shaped Underdeck Clamp -CL
- L Speedi-Set Service Weight
02(50), 03(80), and 04"(100) sizes only (Fig. 1010 only)
- LXH Speedi-Set Extra Heavy
02(50), 03(80), and 04"(100) sizes only (Fig. 1010 only)
- Sump Receiver -R
- Underdeck Clamp -C
- Vandal Proof Dome -U
- T Threaded Outlet

OPTIONAL MATERIALS:

- Aluminum Dome -AD
- Cast Iron Dome -CID
- Galvanized Cast Iron -G
- Rough Bronze Dome -RBD

DRAWING NUMBER
 S1037

SIZE
 A

SCALE:
 NONE

DATE:
 10-8-87

APPROVED BY:
 CR

CHECKED BY:
 BS

DRAWN BY:
 EMB

1037

DIMENSIONS ARE SUBJECT TO MANUFACTURERS TOLERANCE AND CHANGE WITHOUT NOTICE

D	6-506	Revised Dim	TBW	AM
C	5-18-95	Submittal Update	EMB	BS
B	5-90	Chg Dim	TBW	BS
A	2-90	Chg Dim	EMB	BS
REV.	DATE	DESCRIPTION	BY	CKD. BY

WEIGHT POUNDS	VOLUME CUBIC FEET
------------------	----------------------

FIGURE NUMBER
1037