

ROOF DRAINS

SPECIAL ROOF APPLICATIONS

FUNCTION: Used on roof systems where the insulated membrane assembly method of waterproofing is provided, using built-up felt and asphalt. The adjustable extension sleeve permits adjustment from a min. of 1 1/4"(32) to max. of 4 "(100), easily accommodating 2 3/4"(70) of varying insulation thicknesses. The positive threading allows smooth perimeter movement and circumferential support of the top of any adjusted elevation. A 4"(100) high perforated stainless steel gravel guard is supplied to retain the crushed gravel used in flat roof construction.

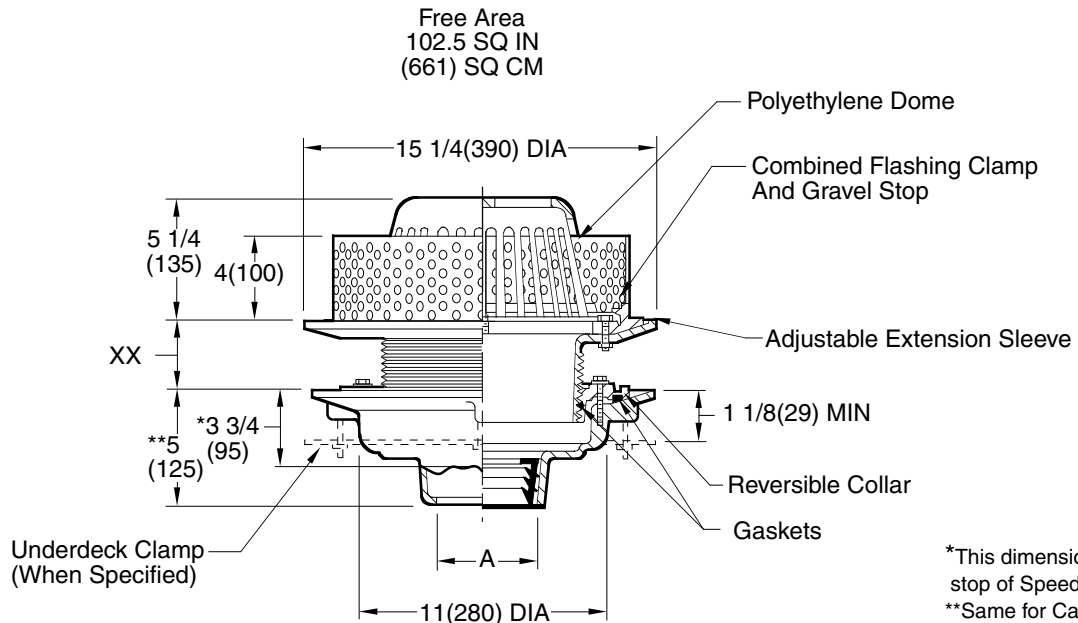

A (Pipe Size) = 02(50), 03(80), 04(100), 05(125) or 06(150)

- Fig. 1031C CAULK OUTLET
- Fig. 1031Y NO-HUB OUTLET

Recommended Deck Opening	
With Suffix -R	17(430) DIA
Less Suffix -R	14(355) DIA

XX	MIN	MAX
LOW POSITION	1 1/4(32)	2 1/2(64)
HIGH POSITION	2 1/4(57)	4 (100)

REGULARLY FURNISHED:
 Duco Cast Iron Body with Adjustable Extension Sleeve, 1/16"(2) Thick 4" (100) High Stainless Steel Perforated Gravel Guard with 3/8"(10) DIA Openings, Flashing Clamp and Polyethylene Dome.

- VARIATIONS:**
- Expansion Joint (Specify Fig. 1710)
 - Higher Gravel Stop (Specify) -HGS
 - "L" Shaped Underdeck Clamp -CL
 - L Speedi-Set Service Weight 02(50), 03(80) & 04"(100) sizes only
 - LXH Speedi-Set Extra Heavy 02(50), 03(80) & 04"(100) sizes only
 - Sump Receiver -R
 - Underdeck Clamp -C
 - Vandal Proof Dome -U
 - T Threaded Outlet

- OPTIONAL MATERIALS:**
- ▲ Aluminum Dome -AD
 - ▲ Cast Iron Dome -CID
 - Galvanized Cast Iron -G
 - ▲ Rough Bronze Dome -RBD

▲ **Optional domes' free area are as follows:**
 Aluminum 98 (632)
 Cast Iron 80 (516)
 Bronze 95 (613)

NOTE: Dimensions shown in parentheses are in millimeters.

DRAWING NUMBER S1031
 SIZE A
 SCALE: NONE
 DATE: 10-8-87
 APPROVED BY: CR
 CHECKED BY: BS
 DRAWN BY: EMB
1031
 DIMENSIONS ARE SUBJECT TO MANUFACTURERS TOLERANCE AND CHANGE WITHOUT NOTICE
 WE CAN ASSUME NO RESPONSIBILITY FOR USE OF SUPERSEDED OR VOID DATA

REV.	DATE	DESCRIPTION	BY	CKD. BY	WEIGHT POUNDS	VOLUME CUBIC FEET	FIGURE NUMBER
C	06/04/09	Added Optional Dome Notes	JJ	CL			1031
B	6-5-06	Revised Dim	TBW	AM			
A	5-17-95	Revised and added millimeters	CMB	BS			