

L



JAY R. SMITH MFG. CO.
 DIVISION OF SMITH INDUSTRIES, INC.
 POST OFFICE BOX 3237
 MONTGOMERY, ALABAMA 36109-0237 (USA)
 TEL: 334-277-8520 FAX: 334-272-7396 www.jrsmith.com



MEMBER OF:



LOCATION

ROOF DRAINS

IRMA ROOF APPLICATIONS

FUNCTION: Used in roof systems where the insulated membrane assembly method of waterproofing is provided. Used where a liquid membrane waterproofing is installed. A stainless steel extension gravel stop at height specified is supplied to retain the crushed gravel used in IRMA flat roof construction.

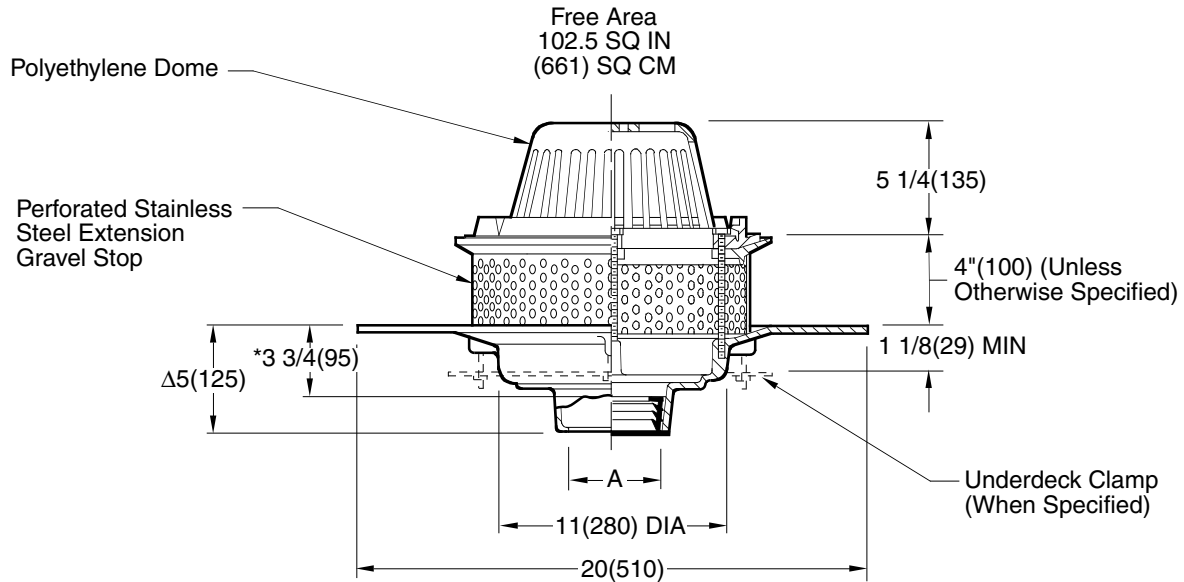

A (Pipe Size) = 02(50), 03(75), 04(100), 05(125) or 06(150)

*This Dimension to Internal Stop of Speedi-Set Gasket.

Fig. 1018C CAULK OUTLET
 Fig. 1018Y NO-HUB OUTLET

ΔSame for Caulk, NO-HUB and Speedi-Set, 3 3/4(95) for Threaded

REGULARLY FURNISHED:

Duco Cast Iron Wide Flange Body with Flashing Clamp, Perforated Stainless Steel Extension, Gravel Stop and Polyethylene Dome.

VARIATIONS:

- Expansion Joint (Specify Fig. 1710)
- Higher Gravel Stop -HGS (Specify Height)
- "L" Shaped Underdeck Clamp -CL
- L Speedi-Set Service Weight 02(50), 03(75) & 04"(100) sizes only
- LXH Speedi-Set Extra Heavy 02(50), 03(75) & 04"(100) sizes only
- Underdeck Clamp -C
- Vandal Proof Dome -U
- T Threaded Outlet

OPTIONAL MATERIALS:

- ▲ Aluminum Dome -AD
- ▲ Cast Iron Dome -CID
- Galvanized Cast Iron Body and Collar -G
- ▲ Galvanized Cast Iron Dome -CIDG
- ▲ Rough Bronze Dome -RBD

▲ Optional domes' free

area are as follows:

Aluminum 98 (632)
 Cast Iron 80 (516)
 Bronze 95 (613)

NOTE: Dimensions shown in parentheses are in millimeters.

DRAWING NUMBER

S1018

SIZE

A

SCALE:

NONE

DATE:

5-24-85

APPROVED BY:

JD

CHECKED BY:

VGD

DRAWN BY:

CR

FIGURE NUMBER

1018

WE CAN ASSUME NO RESPONSIBILITY FOR USE OF SUPERSEDED OR VOID DATA

DIMENSIONS ARE SUBJECT TO MANUFACTURERS TOLERANCE AND CHANGE WITHOUT NOTICE

REV.	DATE	DESCRIPTION	BY	CKD. BY
L	06/03/09	Added Optional Dome Notes	JJ	CL
K	5-26-99	Revised Opt. Mat.	CMD	BS

WEIGHT POUNDS	VOLUME CUBIC FEET

FIGURE NUMBER

1018