

B  
 DRAWING NUMBER S1015-WF  
 SIZE A  
 SCALE: NONE  
 DATE: 1-15-03  
 APPROVED BY: AM  
 CHECKED BY: AM  
 DRAWN BY: RN  
 FIGURE NUMBER 1015-WF

WE CAN ASSUME NO RESPONSIBILITY FOR USE OF SUPERSEDED OR VOID DATA

# GENERAL PURPOSE ROOF DRAINS

## ROOF DRAIN WITH ADJUSTABLE EXTENSION

**FUNCTION:** Used in flat roofs of any construction. The adjustable extension sleeve permits adjustment from a minimum of 1 1/4" (32) to a maximum of 4" (100), easily accommodating up to 2 3/4" (70) of varying insulation thicknesses. The positive threading allows smooth perimeter movement and circumferential support of the top at any adjusted elevation. Large low profile dome provides sufficient free area for quick drainage of rainwater and protection against debris.

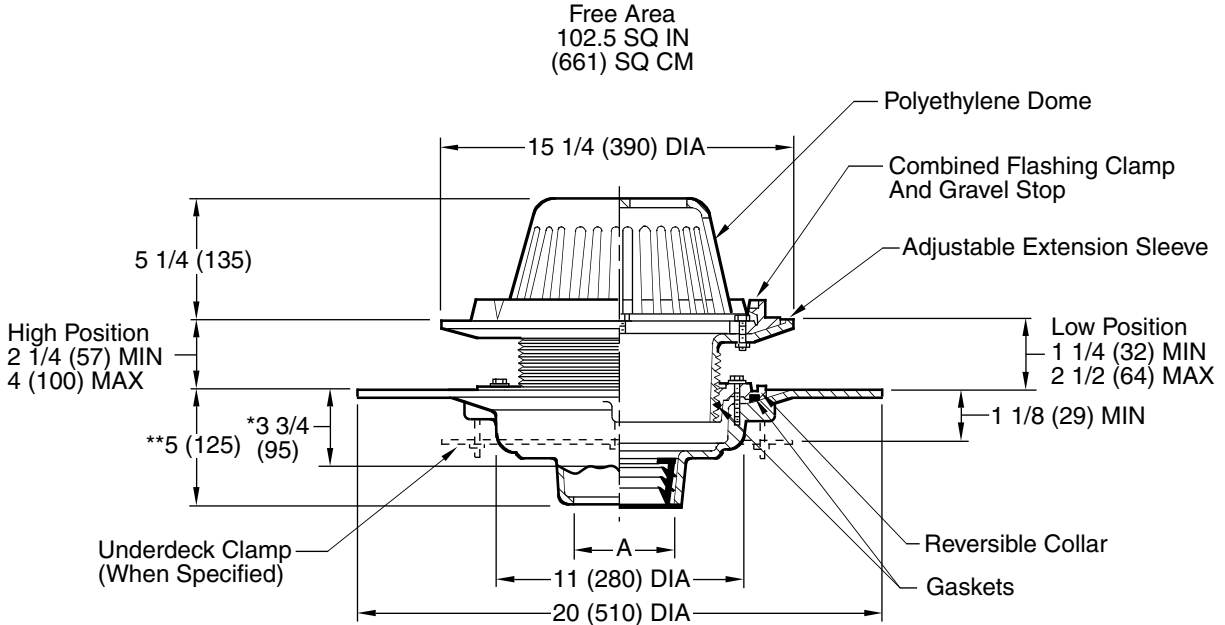

\*This dimension to internal stop of Speedi-Set Gasket  
 \*\*Same for Caulk, NO-HUB and Speedi-Set, 3 3/4 (95) for Threaded

A (Pipe Size) = 02(50), 03(75), 04(100), 05(125) or 06(150)

Fig. 1015C . . . . CAULK OUTLET  
 Fig. 1015Y . . . . NO-HUB OUTLET

recommended deck opening

with suffix -R	17 (430) DIA
less Suffix -R	14 (355) DIA

**REGULARLY FURNISHED:**

Duco Cast Iron Body with Wide Flang And Adjustable Extension Sleeve, Reversible Collar, Combined Flashing Clamp and Gravel Stop, with Polyethylene Dome.

**NOTE:** Dimensions shown in parentheses are in millimeters.

**VARIATIONS:**

- Expansion Joint (Specify Fig. 1710)
- "L" Shaped Underdeck Clamp -CL
- L Speedi-Set Service Weight  
02(50), 03(75) & 04(100)" sizes only
- LXH Speedi-Set Extra Heavy  
02(50), 03(75) & 04(100)" sizes only
- Secondary Flashing Clamp -C2
- Sump Receiver -R
- Underdeck Clamp -C
- Vandal Proof Dome -U
- Side Outlet Drain (Specify Fig. 1025)
- T Threaded Outlet

**OPTIONAL MATERIALS:**

- ▲ Aluminum Dome -AD
- ▲ Cast Iron Dome -CID
- Galvanized Cast Iron -G
- ▲ Rough Bronze Dome -RBD

▲ Optional domes' free area are as follows:

Aluminum	98 (632)
Cast Iron	80 (516)
Bronze	95 (613)

B	06/03/09	Added Optional Dome Notes	JJ	CL	WEIGHT POUNDS	VOLUME CUBIC FEET	FIGURE NUMBER
A	6-6-06	Revised Dim.	TBW	AM			1015-WF
REV.	DATE	DESCRIPTION	BY	CKD. BY			