

E

SMITH® JAY R. SMITH MFG. CO.
 DIVISION OF SMITH INDUSTRIES, INC.
 POST OFFICE BOX 3237
 MONTGOMERY, ALABAMA 36109-0237 (USA)
 TEL: 334-277-8520 FAX: 334-272-7396 www.jrsmith.com



LOCATION

DRAWING NUMBER
S1015 (-E)

SIZE
A

SCALE:
NONE

DATE:
8-14-86

APPROVED BY:
SB

CHECKED BY:
TD

DRAWN BY:
VGD

1015 (-E)

WE CAN ASSUME NO RESPONSIBILITY FOR USE OF SUPERSEDED OR VOID DATA
DIMENSIONS ARE SUBJECT TO MANUFACTURERS TOLERANCE AND CHANGE WITHOUT NOTICE

GENERAL PURPOSE ROOF DRAINS

WITH ADJUSTABLE EXTENSION

FUNCTION: Used in flat roofs of any construction. Large low profile dome provides sufficient free area for quick drainage of rain water and protection against debris. Adjustable extension sleeve and reversible collar allow easy positioning of drain to accommodate varying roof thicknesses. Wide clamping surface holds flashing and roofing material.

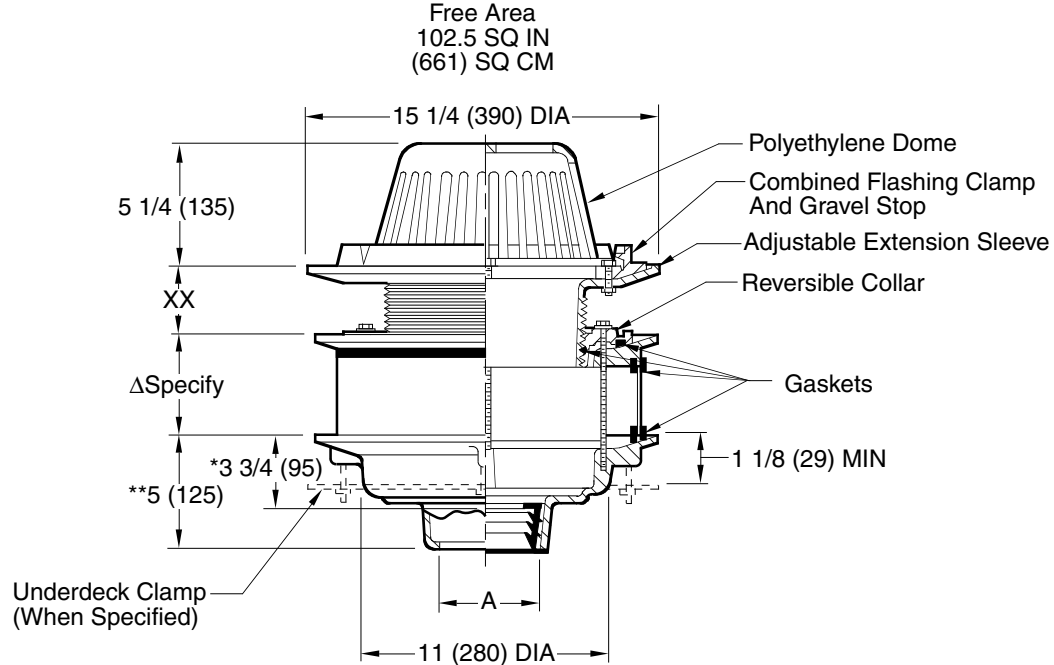

A (Pipe Size) = 02(50), 03(80), 04(100), 05(125), 06(150) or 08(200)

recommended deck opening
with suffix -R 17 (430) DIA
less suffix -R 14 (355) DIA

- Fig. 1015C (-E) CAULK OUTLET
- Fig. 1015Y (-E) NO-HUB OUTLET

XX	MIN	MAX
LOW POSITION	1 1/4 (32)	2 1/4 (57)
HIGH POSITION	2 1/2 (64)	4 (100)

*This dimension to internal stop of Speedi-Set Gasket
 **Same for Caulk, NO-HUB and Speedi-Set, 3 3/4 (95) for Threaded
 ΔExt. thru 4" (100) size will be C.I., over 4" (100) will be fabricated stainless steel. (Fab. SS ext. shown)
NOTE: Dimensions shown in parentheses are in millimeters.

REGULARLY FURNISHED:
 Duco Cast Iron Body with ΔFixed Extension, Adjustable Extension Sleeve, Reversible Collar, Flashing Clamp and Polyethylene Dome.

- VARIATIONS:**
- Expansion Joint (Specify Fig. 1710)
 - "L" Shaped Underdeck Clamp -CL
 - L Speedi-Set Service Weight 02(50), 03(80) & 04"(100) sizes only
 - LXH Speedi-Set Extra Heavy 02(50), 03(80) & 04"(100) sizes only
 - Secondary Flashing Clamp -C2
 - Sump Receiver -R
 - Underdeck Clamp -C
 - Vandal Proof Dome -U
 - With Seepage Holes -WSH
 - T Threaded Outlet

- OPTIONAL MATERIALS:**
- Aluminum Dome -AD
 - Cast Iron Dome -CID
 - Galvanized Cast Iron -G
 - Rough Bronze Dome -RBD

REV.	DATE	DESCRIPTION	BY	CKD. BY
E	6-5-06	Revised Dim. Submittal Update	TBW	AM
D	5-15-95	Rev. Ext	EMB	BS
C	12-88	Revised Note	CMB	TD
B	2-1-88	Added Notes	CMB	TD
A	4-7-87			

WEIGHT POUNDS	VOLUME CUBIC FEET
---------------	-------------------

FIGURE NUMBER
1015 (-E)