

D



JAY R. SMITH MFG. CO.®
 DIVISION OF SMITH INDUSTRIES, INC.
 POST OFFICE BOX 3237
 MONTGOMERY, ALABAMA 36109-0237 (USA)
 TEL: 334-277-8520 FAX: 334-272-7396 www.jrsmith.com



MEMBER OF:

LOCATION

DRAWING NUMBER
S1002

SIZE
A

SCALE:
NONE

DATE:
4-11-94

APPROVED BY:
JCS

CHECKED BY:
CS

DRAWN BY:
EMB

WE CAN ASSUME NO RESPONSIBILITY FOR USE OF SUPERSEDED OR VOID DATA

DIMENSIONS ARE SUBJECT TO MANUFACTURERS TOLERANCE AND CHANGE WITHOUT NOTICE

UNIVERSAL ROOF DRAIN MEMBRANE CLAMPING COLLAR

FUNCTION: Universal cast iron membrane clamping collar designed for retrofit roof applications where the existing main roof drain body is to remain in place and continue to be operative. The bolting lugs of this collar match the bolt pattern of the majority of the common roof drain bodies and generally conform to the surface angles of the flange. This allows easy replacement along with adequate pressure on the membrane to insure water tightness. The collar is designed to accompany most 15"(380) and 16"(405) diameter roof drain bodies with bolt circles ranging 7 1/4"(185) to 10 3/4"(275) in diameter. It is recommended to extend roof membrane into the sump of existing roof drain body.

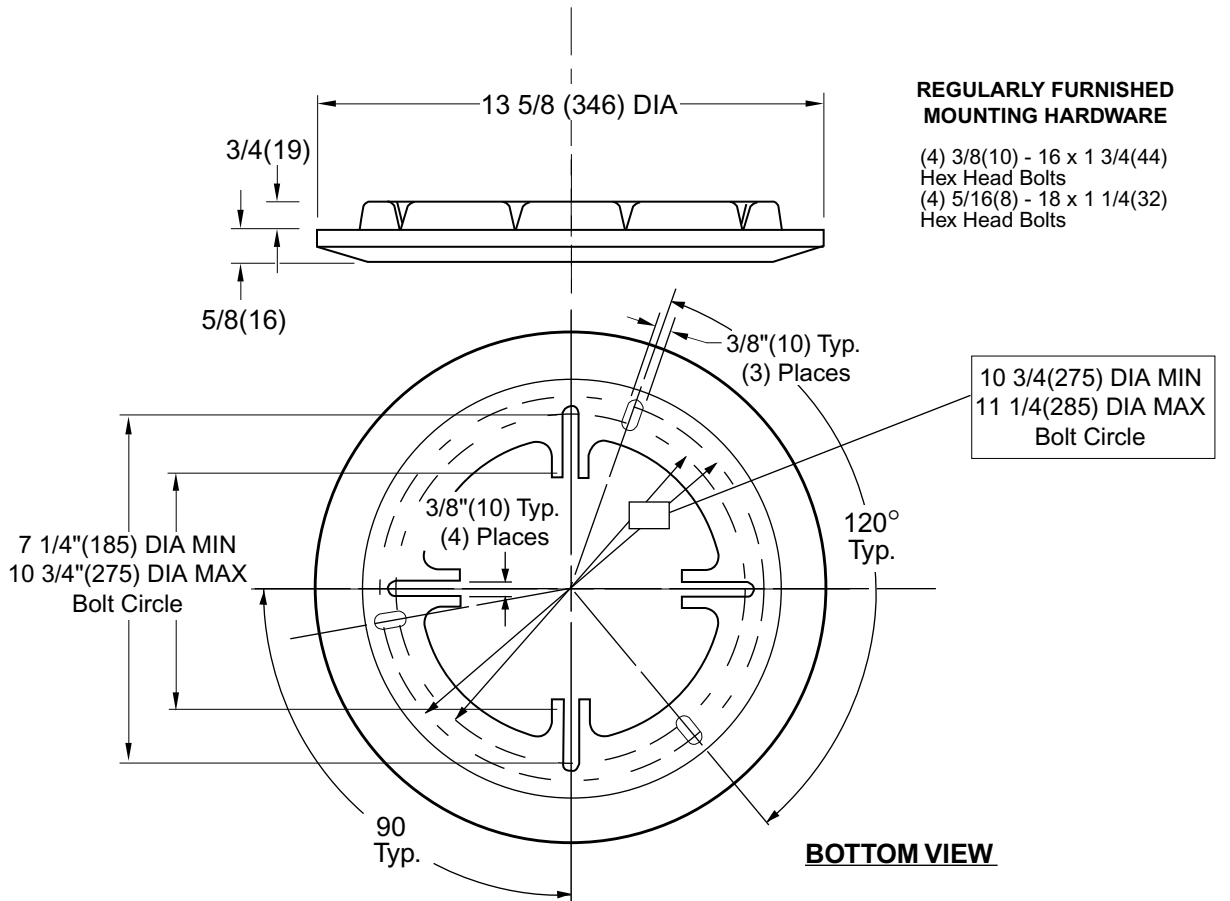

REGULARLY FURNISHED:
 Duco Coated Universal Cast Iron Membrane Clamping Collar with Mounting Hardware.

- VARIATIONS:**
- Perf. S.S. Gravel Guard (Specify Height)
 - Solid Water Dam Collar -WD (Specify Height)
 - Vandal Proof Dome -U (When dome is specified)

OPTIONAL MATERIALS:
 Galvanized Cast Iron Collar -CG

NOTE: Dimensions shown in parentheses are in millimeters.

1002

D	5-26-99	Revised Opt. Materials	CMD	BS	WEIGHT POUNDS	VOLUME CUBIC FEET	FIGURE NUMBER 1002
C	10-7-96	Added Millimeters	EMB	BS			
B	7-19-94	Submittal Update	EMB	BS			
A	5-4-94	Rev Reg Furn & Opt Mat	EMB	JCS			
REV.	DATE	DESCRIPTION	BY	CKD. BY			