

BACKWATER VALVES

FIG. 7000 PIT STYLE BACKWATER VALVE

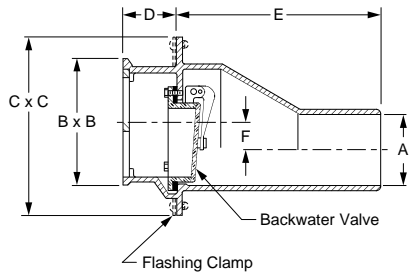

FUNCTION: Used at the base of side walls in pits, where low elevation requires a vertical inlet grate and side outlet roughing. Backwater valve provides protection against backflow which could damage equipment in pit.



OPTIONS:

	03, 04"	05, 06"	ADD 08"
-C Flashing Clamp	161.00	161.00	286.00
-G Galvanized CI	400.00	400.00	650.00
-U Vandal Proof Screws	89.00	89.00	89.00
Stainless Steel	Specify Fig. 9790		

A OUTLET SIZE	B X B FACE SIZE	C X C	D	E	F	FREE AREA SQ. IN.	†DUCO CI	DUCO CI PB FACE	DUCO CI NB FACE	APPROX. WEIGHT LBS	ADD FOR CP FACE
03, 04"	6 3/4" x 9 1/2"	10 1/4" x 12"	3"	11 1/4"	2 3/4"	15	1,116.00	1,468.00	1,642.00	43	689.00
05, 06"	7 3/4" x 11"	9 3/4" x 13"	4"	13 1/4"	1 1/4"	24 1/2	1,676.00	2,028.00	2,202.00	70	901.00
08"	12 1/2" x 14 1/2"	17 1/4" x 19"	4"	22"	4 3/4"	56	3,261.00	4,287.00	4,395.00	150	1,574.00

REGULARLY FURNISHED: Duco Cast Iron Body with Backwater Valve and Cast Iron Secured Gate.

FIG. 7012 SER. SEWER VALVE W/BOLTED COVER (7012) OR THREADED COVER (7022)

FUNCTION: Used in main or branch sewer lines to protect basements and low areas against backflow from the street sewers. Valve design permits access to backwater valve assembly, for servicing or cleaning, through a "full opening" bolted cover or threaded cover.

OUTLET VARIATIONS (Specify type of outlet and pipe size in inches.)

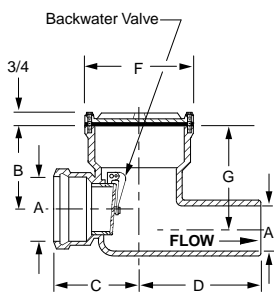

Fig. 7012 Bolted Cover

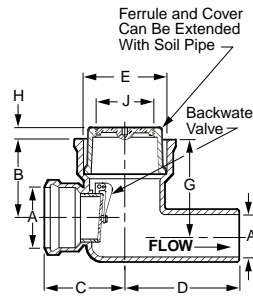

Fig. 7022 Threaded Cover

Outlet Type	Outlet Designation Outlet Type/Pipe Size	ADD
Y	No-Hub Inlet and Outlet	N/C
	Y02, Y03, Y04, Y05, Y06, Y08, Y10,	POA
	Y12	POA

OPTIONS:

	ADD
-G Galvanized Cast Iron	
02, 03, 04"	319.00
05, 06"	536.00
08, 10"	957.00
12"	1,179.00

Stainless Steel (Fig. 7012 Only) Specify Fig. 9795

A* OUTLET SIZE	B	C	D	E SIZE	F DIA	G	H	J SIZE	7012 DUCCO CI BRZ VALVE	7022 DUCCO CI BRZ VALVE	APPROX. WEIGHT LBS
02"	4 1/2"	5"	7"	4"	6 1/2"	6"	1 1/4"	3 1/2"	791.00	791.00	22
03"	6 1/4"	5 3/4"	9"	5"	7 1/2"	7 1/2"	1 1/2"	4"	1,239.00	1,239.00	29
04"	6 1/2"	6 1/2"	9 1/2"	6"	8 1/2"	8"	1"	5"	1,525.00	1,525.00	41
05"	7"	7 3/4"	10 1/2"	8"	10 3/4"	8 3/4"	1"	6"	1,834.00	1,834.00	54
06"	8"	7 3/4"	11 1/2"	8"	10 3/4"	9 3/4"	1"	6"	2,191.00	2,191.00	75
08"	9 1/2"	9 1/2"	12 1/2"	10"	13"	11 3/4"	1"	6"	3,079.00	3,079.00	100
**10"									10,464.00	-	125
**12"									10,788.00	-	150

REGULARLY FURNISHED: Duco Cast Iron Body with Bronze Backwater Valve. Cover as Indicated by Figure Number Selected.

*Sized for Service Weight and/or No-Hub.
**Please contact Jay R. Smith Engineering Department for dimensions not shown.

BACKWATER VALVES

BACKWATER VALVES

FIG. 7070 TERMINAL VALVE



FUNCTION: Used at the end of sewer lines, which discharge into manholes, catch basins, drainage lagoons and seawalls to prevent backflow into areas which are to be drained.

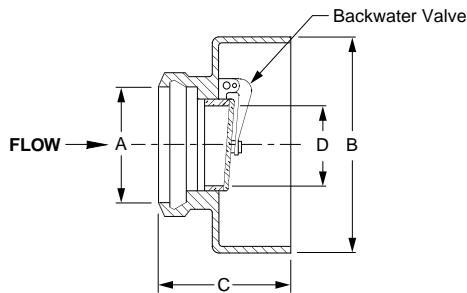

Outlet Type	Outlet Designation Outlet Type/Pipe Size	ADD
C	Inside Caulk	N/C
Y	No-Hub Outlet	N/C

A* OUTLET SIZE	B DIA	C	D	†DUCO CI BRZ VALVE	GALV CI BRZ VALVE	APPROX. WEIGHT LBS
02"	6 1/4"	5 1/4"	1 3/4"	330.00	516.00	10
03"	8"	5 1/2"	2 3/4"	330.00	516.00	12
04"	9"	5 3/4"	3 3/4"	481.00	667.00	15
05"	11 1/2"	6"	4 1/2"	1,147.00	1,410.00	20
06"	11 1/2"	6"	5 3/4"	1,373.00	1,636.00	28
08"	13 1/2"	6 3/4"	8"	1,671.00	2,216.00	42
10"	15 3/4"	7 3/4"	10"	5,023.00	5,568.00	58
12"	17 1/2"	8 3/4"	12"	5,668.00	6,309.00	80
16"	26 1/4"	16 1/2"	18"	10,746.00	POA	120

REGULARLY FURNISHED: Duco Cast Iron Body with Backwater Valve.

FIG. 7080 SER. DRAIN OUTLET VALVE W/SPIGOT (7080) OR THREADED (7082) OUTLET

FUNCTION: Installed as independent backwater protection for bottom outlet floor drains to prevent damaging backflow from entering room where floor drain is installed.

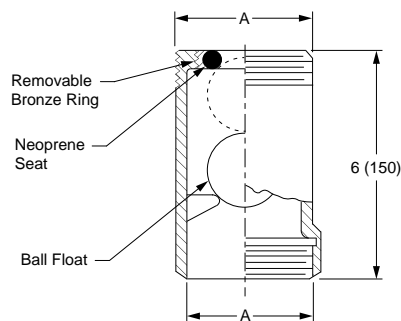

Outlet Type	Outlet Designation Outlet Type/Pipe Size	ADD
Y	No-Hub Outlet (7080 Only)	N/C

OPTIONS:	ADD
-BB All Bronze	POA

A OUTLET SIZE	†DUCO CI	GALV CI	APPROX. WEIGHT LBS
02"	353.00	417.00	3
03, 04"	353.00	417.00	6
05, 06"	730.00	894.00	23

REGULARLY FURNISHED:
Duco Cast Iron Body with Ball Float
Backwater Valve.

BACKWATER VALVES

FIG. 7097 DRAIN TILE SUMP WITH 4" TILE INLET & SPIGOT OUTLET

FUNCTION: Provides a sump with multiple inlets into which the foundation drain tile lines are connected.

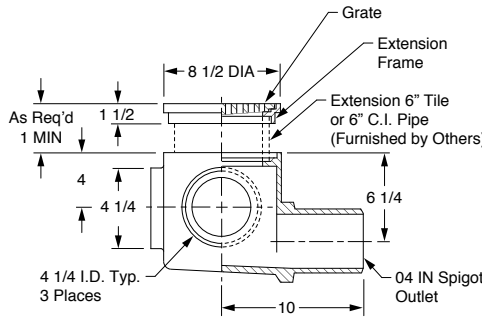

OPTIONS:

	ADD
-G Galvanized CI	428.00
-NB Nickel Bronze Top.....	593.00
-PB Polished Bronze Top.....	459.00
-SC Solid CI Cover	150.00

A OUTLET SIZE	FREE AREA SQ. IN.	†DUCO CI	APPROX. WEIGHT LBS
04"	14.25"	595.00	55

REGULARLY FURNISHED:

Duco Cast Iron Body and Extension Frame with Cast Iron Slotted Grate.

FIG. 7140 FLOOD-GATE® IN-LINE AUTOMATIC BACKWATER VALVE

FUNCTION: Functions as a drainage control valve providing "closure" protection during emergency storm conditions or when building is completely shut down. The FLOOD-GATE® does not have to be activated as no electronics are required for valve operation. The valve is completely automatic both closing and resetting. Once closed it prevents any leakage beyond the gate. Applications include all commercial, institutional, residential and industrial installations including basements and elevator pits.

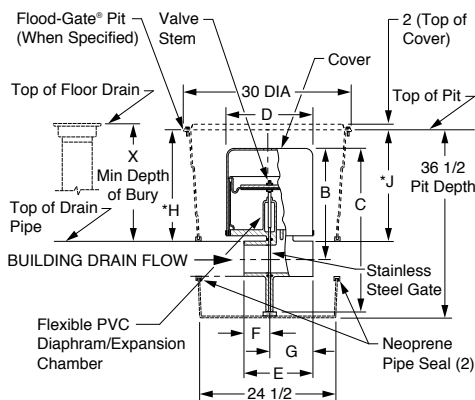

OPTIONS:

FGA	Complete Alarm System
FGP	Poly Pit and Lid, with Hardware
FGS	Poly Pit with Steel Lid with Hardware
FGSL	Steel Pit Lid Only

U.S. Patent No. 5,538,032
Other U.S. and foreign patents pending

Conforms to ASME A112.14.1-2003
IAPMO Listed, File No. 3758

For Pricing information on this Product Series contact your local Jay R. Smith Mfg. Co. representative.

A DIA NO-HUB (-Y) IN/OUT SIZE	B CENTERLINE TO TOP	C OVERALL HEIGHT	D DIA WIDTH	E LENGTH	F INLET LENGTH	G OUTLET LENGTH	*H	*J	X MIN BURY DEPTH	BASE WIDTH
04"	15"	22 15/16"	12 5/8"	6 5/8"	2 3/8"	4 1/4"	26 1/4"	26 3/4"	9"	7 1/2"
06"	20 3/8"	31 1/4"	13 1/4"	8 3/16"	3 3/16"	5"	22 1/4"	22 3/4"	14"	9 1/2"

REGULARLY FURNISHED: Duco Coated Cast Iron Body Complete with Stainless Steel Gate and Flexible PVC Diaphragm/Expansion Chamber.

*Dimension can be decreased by up to 10" for the 4" size and 3" for the 6" size by cutting the pit and telescoping the 2 sections to meet required depth. See instructions supplied with pit.

BACKWATER VALVES AND TRAPS

FIG. 7150 IN-LINE MANUAL SHUT-OFF VALVE



FUNCTION: Functions as a drainage control valve; flapper type backwater valve provides temporary protection against sewage backflow surges. Manually closed "spade" type gate valve provides additional complete "closure" protection during emergency conditions, when building is completely shut down or during extended periods of backflow conditions.

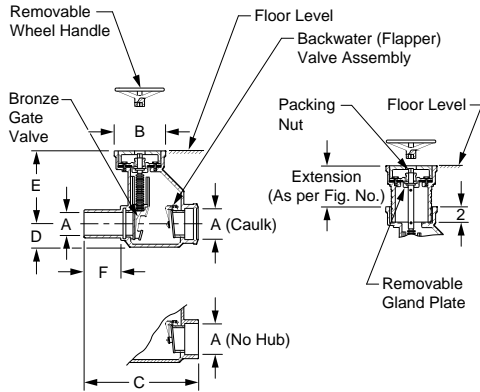

INLET VARIATIONS

Inlet Type	ADD
Caulk.....	N/C
No-Hub.....	N/C
OPTIONS:	DEDUCT
-LW Less Wheel Handle.....	43.00
-SW Sized for Service Weight.....	N/C

FIGURE NO.	EXTENSION	A OUTLET SIZE	B DIA.	C	D	E	F	†DUCO CI BRZ VALVE	GALV CI BRZ VALVE	APPROX. WEIGHT LBS
7150	-	04"	8"	18"	3 3/4"	12"	5"	3,056.00	3,871.00	110
	-	06"	10 1/2"	20"	4 1/2"	14 1/2"	5"	4,502.00	5,317.00	140
7151	12"	04"	8"	18"	3 3/4"	12"	5"	4,316.00	5,131.00	110
7152	24"	04"	8"	18"	3 3/4"	12"	5"	5,574.00	6,389.00	130
7153	9 1/2"	06"	10 1/2"	20"	4 1/2"	14 1/2"	5"	5,760.00	6,575.00	140
7154	21 1/2"	06"	10 1/2"	20"	4 1/2"	14 1/2"	5"	7,019.00	7,834.00	160
7155	Adaptor	04"	8"	18"	3 3/4"	12"	5"	3,968.00	4,783.00	110
	Adaptor	06"	10 1/2"	20"	4 1/2"	14 1/2"	5"	5,592.00	6,407.00	115

REGULARLY FURNISHED: Duco Cast Iron Body and Cover with Removable Wheel Handle. Bronze Gate and Bronze Flapper Valve. Cast Iron Extensions as Indicated by Figure Number Selected.

FIG. 7220, 7221 DEEP SEAL "P" TRAPS W/FEMALE THREADED INLET AND OUTLET (7220) OR MALE THREADED INLET AND FEMALE THREADED OUTLET (7221)

FUNCTION: Provides the protection of an independent "deep seal" cast iron trap for use in conjunction with bottom outlet drains. Can be provided with bottom cleanout plug, trap primer connection or low flushing tapping.

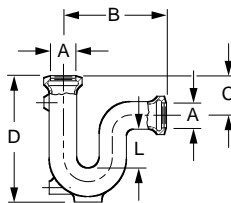

Fig. 7220

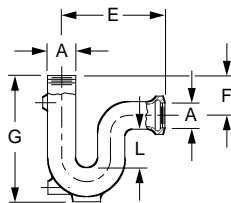

Fig. 7221

OPTIONS:	ADD
-BP Bronze Cleanout Plug.....	124.00
-FC Flushing Connection.....	90.00
-P Trap Primer Conn.....	90.00

A OUTLET SIZE	B	C	D	E	F	G	L SEAL	†DUCO CI	GALV CI	ARC CI INSIDE	ALL BRONZE (-BB)	APPROX. WEIGHT LBS
02"	6 1/4"	2 3/4"	10"	6 1/4"	2 3/4"	10"	4"	266.00	341.00	378.00	POA	10
03"	8"	3"	13"	8"	3"	13"	5"	408.00	587.00	617.00	POA	20
04"	9 3/4"	4 1/4"	15 1/2"	9 3/4"	6"	17 1/2"	5"	613.00	895.00	909.00	POA	33

REGULARLY FURNISHED: Duco Cast Iron Trap.

TRAPS

FIG. 7222, DEEP SEAL "P" TRAP WITH HUB INLET AND SPIGOT OUTLET



FUNCTION: Provides the protection of an independent "deep seal" cast iron trap for use in conjunction with bottom outlet drains. Can be provided with bottom cleanout plug, trap primer connection or low flushing tapping.

7222
Same as
7220 but with
Hub Inlet and
Spigot Outlet

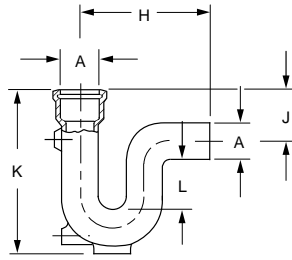

OPTIONS:	ADD
-BP Bronze Cleanout Plug	124.00
-FC Flushing Connection	90.00
-P Trap Primer Conn	90.00
-Y No-Hub Adaptor	See Fig. 2646Y

A OUTLET SIZE	H	J	K	L SEAL	†DUCO CI	GALV CI	ARC CI INSIDE	ALL BRONZE (-BB)	APPROX. WEIGHT LBS
02"	10"	4"	11 1/2"	4"	266.00	341.00	378.00	POA	10
03"	11 1/2"	4 1/2"	14 1/2"	5"	408.00	587.00	617.00	POA	20
04"	14 3/4"	7"	18 1/2"	5"	613.00	895.00	909.00	POA	33

REGULARLY FURNISHED: Duco Cast Iron Trap.

FIG. 7230, 7231, 7232 DEEP SEAL TRAP WITH FLOOR CLEANOUT

FUNCTION: Provides the protection of an independent "deep seal" cast iron trap when used in conjunction with bottom outlet drains. Integral hub at crown of the trap permits the installation of a suitable floor level cleanout.

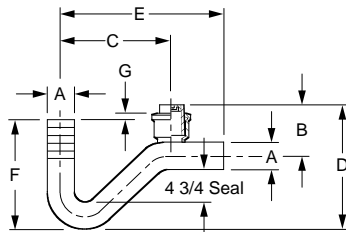

Fig. 7230

Adjustable Housing
With Tractor Cover

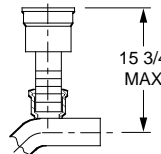

Fig. 7231

Extension Ferrule
With Cleanout Plug

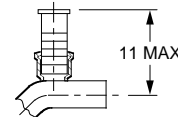

Fig. 7232

FIGURE NO.	A OUTLET SIZE	B	C	D	E	F	G	†DUCO CI	GALV CI	APPROX. WEIGHT LBS
7230	02"	6"	11"	13 3/4"	16 1/2"	12 1/2"	1/4"	642.00	961.00	37
	03"	7 3/4"	14 1/2"	15 3/4"	21 3/4"	14"	3/4"	823.00	1,142.00	37
	04"	8 1/2"	14 1/2"	18 1/2"	21 1/2"	16"	1 1/4"	932.00	1,251.00	42
7231	02"	6"	11"	13 3/4"	16 1/2"	12 1/2"	1/4"	784.00	1,103.00	56
	03"	7 3/4"	14 1/2"	15 3/4"	21 3/4"	14"	3/4"	1,007.00	1,326.00	56
	04"	8 1/2"	14 1/2"	18 1/2"	21 1/2"	16"	1 1/4"	1,167.00	1,486.00	58
7232	02"	6"	11"	13 3/4"	16 1/2"	12 1/2"	1/4"	642.00	961.00	43
	03"	7 3/4"	14 1/2"	15 3/4"	21 3/4"	14"	3/4"	823.00	1,142.00	43
	04"	8 1/2"	14 1/2"	18 1/2"	21 1/2"	16"	1 1/4"	932.00	1,251.00	70

REGULARLY FURNISHED: Duco Cast Iron Body and Ferrule with Bronze Cleanout Plug.

BACKWATER VALVES