

LABOR SAVER™ HEAVY DUTY FIXTURE SUPPORT FLOOR MOUNTED

WITH SUPPORTING STUDS, ADJUSTABLE COUPLING AND WASTE FITTING

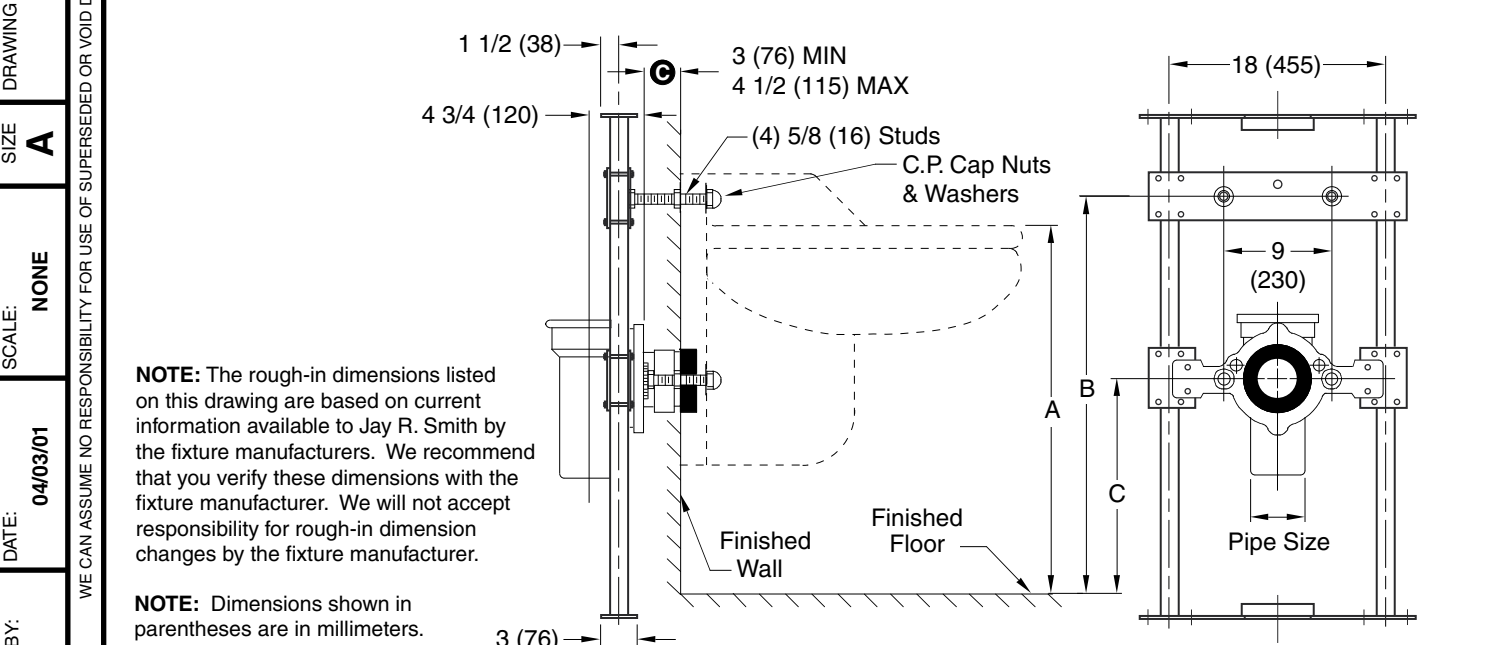

NOTE: The rough-in dimensions listed on this drawing are based on current information available to Jay R. Smith by the fixture manufacturers. We recommend that you verify these dimensions with the fixture manufacturer. We will not accept responsibility for rough-in dimension changes by the fixture manufacturer.

NOTE: Dimensions shown in parentheses are in millimeters.

⊙ This dimension can be increased when fixture support is to be installed behind the wall (specify when required and wall thickness.)

*SPECIFY SIZE AND TYPE OF FITTING

The water closet gasket regularly furnished is made of molded neoprene and designed to fit water closet outlet dimensions and configurations shown in ANSI Standard A112.19.2M-1982, Figure 13B. If gasket is not found to be compatible to fixture due to nonconformance of said fixture to ANSI A112.19.2M, then fixture manufacturer shall be consulted for a suitable gasket recommendation. Jay R. Smith assumes no liability for connections to fixtures which do not conform to these standards.

Fig. 0925 . . . WITH SUPPORTING STUDS, ADJUSTABLE COUPLING AND WASTE FITTING 4" (100) CAULK AND 4" (100) VENT FOR BACK OUTLET FLUSHING RIM SERVICE SINK

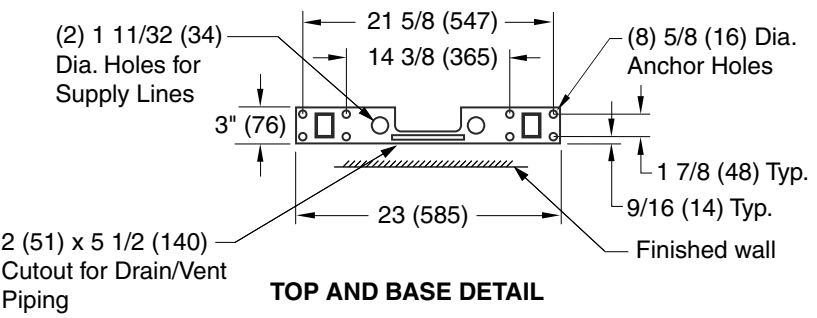

ROUGHING-IN TABLE

FIXTURE MFG.	NAME	NUMBER	SIZE	A	B	C

0925

FIGURE NUMBER	C B A	11/08/02 08/05/02 12/19/01	Changed per George Flegel Added Stud Connection to Plate Changed Hole Size in Base	JJ JJ JJ	AM AM AM	WEIGHT POUNDS	VOLUME CUBIC FEET	FIGURE NUMBER 0925
REV.	DATE	DESCRIPTION	BY	CKD. BY				

DRAWING NUMBER S0925 (B)
 SIZE A
 SCALE: NONE
 DATE: 04/03/01
 APPROVED BY: AM
 CHECKED BY: CR
 DRAWN BY: JJ
 DIMENSIONS ARE SUBJECT TO MANUFACTURERS TOLERANCE AND CHANGE WITHOUT NOTICE
 WE CAN ASSUME NO RESPONSIBILITY FOR USE OF SUPERSEDED OR VOID DATA