

B

SMITH® JAY R. SMITH MFG. CO.
 DIVISION OF SMITH INDUSTRIES, INC.
 POST OFFICE BOX 3237
 MONTGOMERY, ALABAMA 36109-0237 (USA)
 TEL: 334-277-8520 FAX: 334-272-7396 www.jrsmith.com



LOCATION

LAVATORY SUPPORTS

WALL MOUNTED

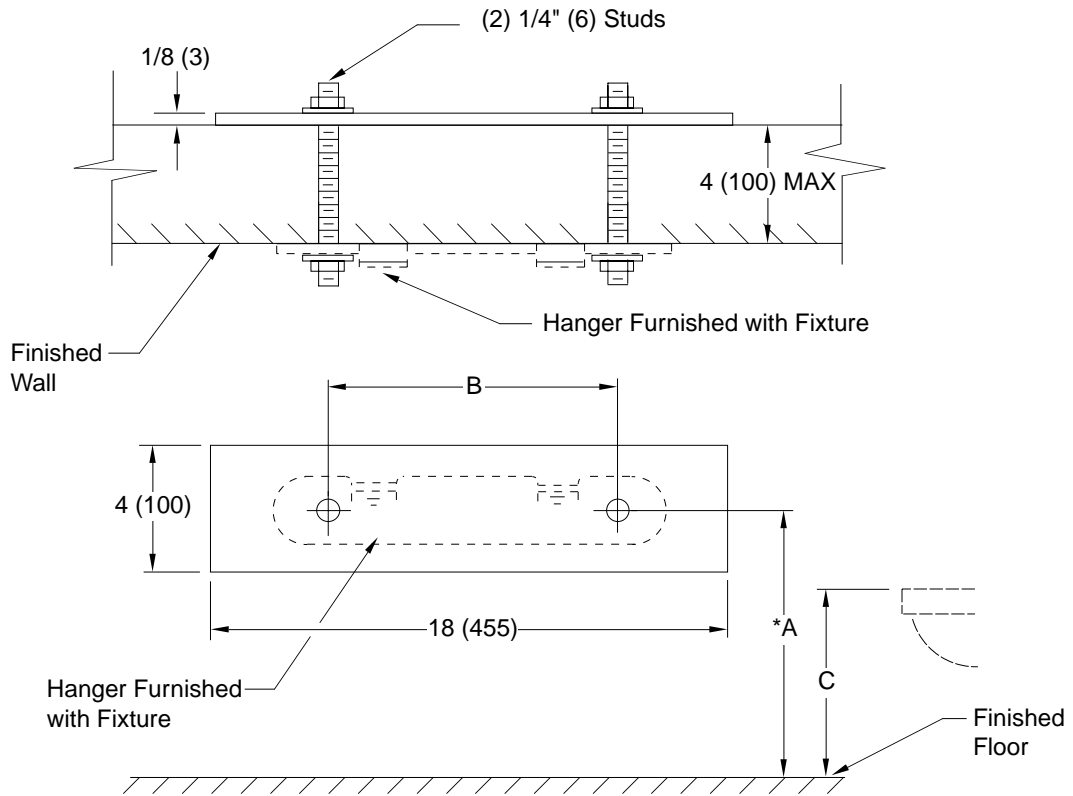

Fig. 0826 . . . SINGLE REINFORCING PLATE FOR HIGH BACK LAVATORIES WITH CONCEALED HANGER.

***NOTE:** This dimension is based on a rim to finish floor height of 31" (785).

ROUGHING-IN TABLE

FIXTURE NAME	NUMBER	SIZE	A	B	C

NOTE: The rough-in dimensions listed on this drawing are based on current information available to Jay R. Smith by the fixture manufacturers. We recommend that you verify these dimensions with the fixture manufacturer. We will not accept responsibility for rough-in dimension changes by the fixture manufacturer.

NOTE: Dimensions shown in parentheses are in millimeters.

DRAWING NUMBER
S0826 (B)

SIZE
A

SCALE:
NONE

DATE:
12-18-85

APPROVED BY:
SJM

CHECKED BY:
JD

DRAWN BY:
JD

0826

WE CAN ASSUME NO RESPONSIBILITY FOR USE OF SUPERSEDED OR VOID DATA
DIMENSIONS ARE SUBJECT TO MANUFACTURERS TOLERANCE AND CHANGE WITHOUT NOTICE

B	4-3-97	Added Millimeters	EMB	BS	WEIGHT POUNDS	VOLUME CUBIC FEET	FIGURE NUMBER
A	8-17-93	Submittal Update	EMB	BS			
REV.	DATE	DESCRIPTION	BY	CKD. BY			

0826