

# LAVATORY SUPPORTS

## WALL MOUNTED TYPE

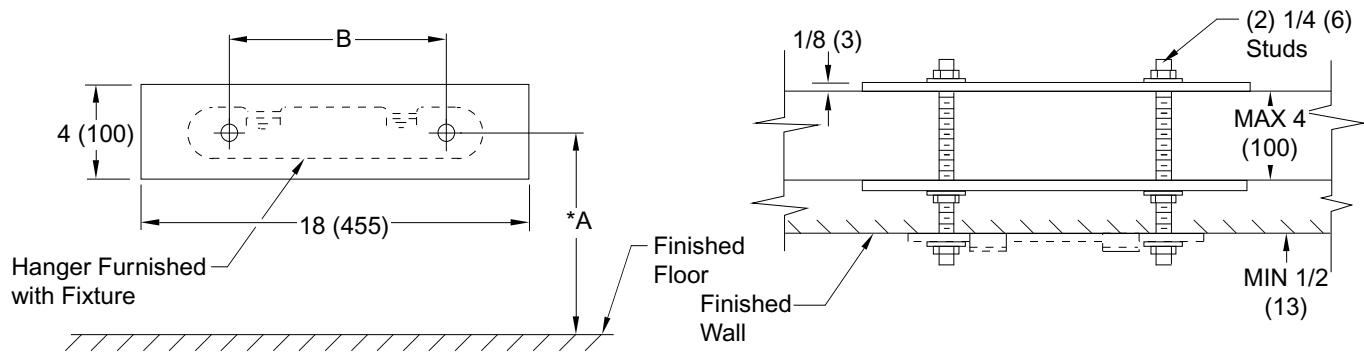

Fig. 0825 . . . DOUBLE REINFORCING PLATES FOR HIGH BACK LAVATORIES WITH CONCEALED HANGER

### ROUGHING-IN TABLE

FIXTURE MFG.	NAME	NUMBER	SIZE	A	B
AM. STD.	LUCERNE	0350.025	20 x 18 (510 x 455)	32 1/8 (816)	9 5/8 (245)
AM. STD.	LUCERNE	0350.124	20 x 18 (510 x 455)	32 1/8 (816)	9 5/8 (245)
AM. STD.	LUCERNE	0350.231	20 x 18 (510 x 455)	32 1/8 (816)	9 5/8 (245)
AM. STD.	LUCERNE	0350.496	24 x 20 (610 x 510)	33 3/8 (848)	9 5/8 (245)
AM. STD.	LUCERNE	0351.023	20 x 18 (510 x 455)	32 1/8 (816)	9 5/8 (245)
AM. STD.	LUCERNE	0351.197	24 x 20 (610 x 510)	33 3/8 (848)	9 5/8 (245)
CRANE	NORWICH	1-185	20 x 18 (510 x 455)	32 1/4 (820)	10 (255)
CRANE	NORWICH	1-194, 5	18 x 15 (455 x 380)	32 1/4 (820)	10 (255)
CRANE	NORWICH	1-194,5, 1-206	20 x 18 (510 x 455)	32 1/4 (820)	10 (255)
CRANE	NORWICH	1-194, 5	24 x 21 (610 x 535)	32 1/4 (820)	10 (255)
ELJER	DELWYN	051-1614, 1818	20 x 18 (510 x 455)	32 (815)	8 7/8 (225)
ELJER	DELWYN	051-1624, 1828	24 x 20 (610 x 510)	33 (840)	8 7/8 (225)
KOHLER	GRAMERCY	K-1607	19 x 17 (485 x 430)	32 1/2 (825)	9 1/4 (235)
KOHLER	GRAMERCY	K-1607	22 x 18 (560 x 455)	32 1/2 (825)	9 1/4 (235)
KOHLER	CHESAPEAKE	K-1746, 8	19 x 17 (485 x 430)	29 3/4 (755)	9 1/4 (235)
KOHLER	CHESAPEAKE	K-1746, 8	20 x 18 (510 x 455)	29 3/4 (755)	9 1/4 (235)
KOHLER	GREENWICH	K-2030,1,2,4,6	20 x 18 (510 x 455)	33 1/4 (845)	9 1/4 (235)
KOHLER	GREENWICH	K-2030,1,2,4,6	24 x 20 (610 x 510)	33 1/4 (845)	9 1/4 (235)

**\*NOTE:** This dimension is based on a rim to finish floor height of 31" (785).  
**NOTE:** Dimensions shown in parenthesis are in millimeters.

**NOTE:** The rough-in dimensions listed on this drawing are based on current information available to Jay R. Smith by the fixture manufacturers. We recommend that you verify these dimensions with the fixture manufacturer. We will not accept responsibility for rough-in dimension changes by the fixture manufacturer.

DRAWING NUMBER **S0825**  
 SIZE **A**  
 SCALE: **NONE**  
 DATE: **1-14-75**  
 APPROVED BY:  
 CHECKED BY: **RS**  
 DRAWN BY: **RAS**  
**0825**  
 FIGURE NUMBER

WE CAN ASSUME NO RESPONSIBILITY FOR USE OF SUPERSEDED OR VOID DATA

	<b>D</b>	<b>8-17-93</b>	<b>Submittal Update</b>	<b>EMB</b>	<b>BS</b>	WEIGHT POUNDS	VOLUME CUBIC FEET	<b>FIGURE NUMBER</b>
REV.	DATE	DESCRIPTION	BY	CKD. BY				<b>0825</b>

# LAVATORY SUPPORTS

## WALL MOUNTED

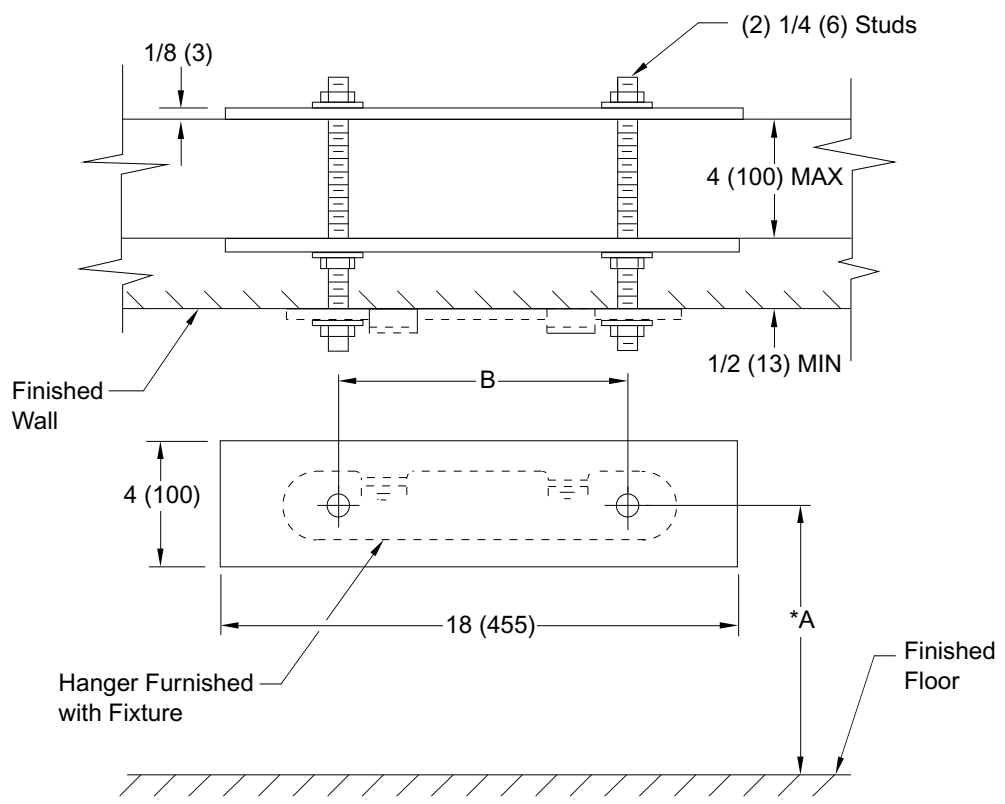

**Fig. 0825 . . . DOUBLE REINFORCING PLATES FOR HIGH BACK LAVATORIES WITH CONCEALED HANGER**

**\*NOTE:** This dimension is based on a rim to finish floor height of 31" (785).  
**NOTE:** Dimensions shown in parentheses are in millimeters.

### ROUGHING-IN TABLE

FIXTURE NAME	NUMBER	SIZE	A	B

**NOTE:** The rough-in dimensions listed on this drawing are based on current information available to Jay R. Smith by the fixture manufacturers. We recommend that you verify these dimensions with the fixture manufacturer. We will not accept responsibility for rough-in dimension changes by the fixture manufacturer.

DRAWING NUMBER: S0825 (B)  
 SIZE: A  
 SCALE: NONE  
 DATE: 1-14-75  
 APPROVED BY:  
 CHECKED BY: RS  
 DRAWN BY: RAS  
 FIGURE NUMBER: 0825  
 DIMENSIONS ARE SUBJECT TO MANUFACTURERS TOLERANCE AND CHANGE WITHOUT NOTICE

WE CAN ASSUME NO RESPONSIBILITY FOR USE OF SUPERSEDED OR VOID DATA

REV.	DATE	DESCRIPTION	BY	CKD. BY	WEIGHT POUNDS	VOLUME CUBIC FEET	<b>FIGURE NUMBER</b> <span style="font-size: 2em;"><b>0825</b></span>
E D	4-3-97 8-17-93	Added Millimeters Submittal Update	EMB EMB	BS BS			