

<b>B</b>	<b>SMITH® JAY R. SMITH MFG. CO.</b> DIVISION OF SMITH INDUSTRIES, INC. POST OFFICE BOX 3237 MONTGOMERY, ALABAMA 36109-0237 (USA) TEL: 334-277-8520 FAX: 334-272-7396 www.jrsmith.com	MEMBER OF: 	<b>LOCATION</b>
----------	--	----------------	-----------------

## LAVATORY SUPPORTS WITH EXPOSED ARMS

### WALL MOUNTED WITH ACID RESISTANT COATED EXPOSED ARMS

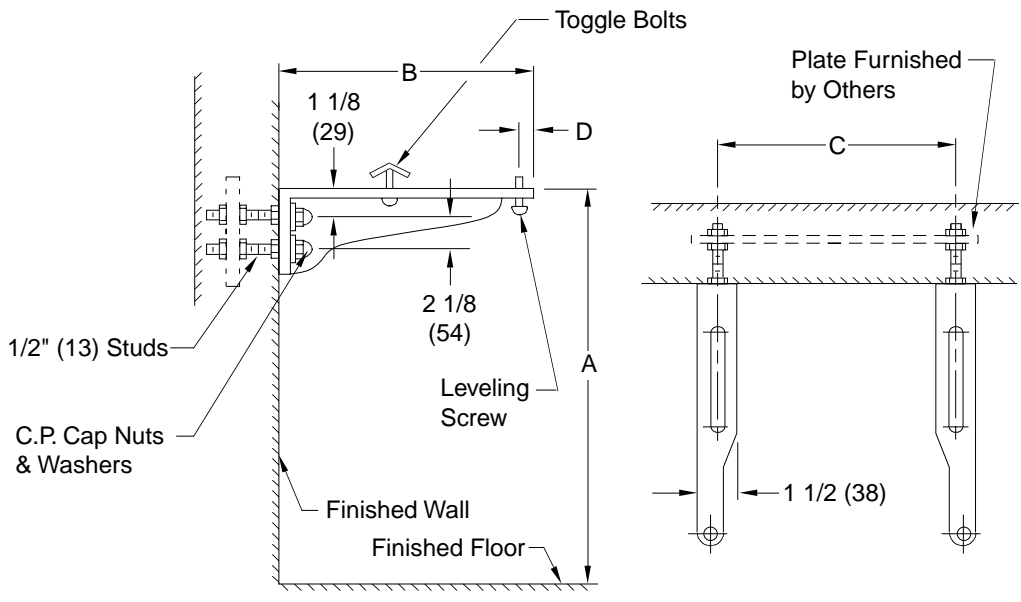

**Fig. 0790 . . . FOR FLAT SLAB AND HIGH BACK LAVATORIES TO ATTACH TO BACKING PLATE SECURED IN WALL**

**ROUGHING-IN TABLE**

FIXTURE NAME	NUMBER	SIZE	A	B	C	D

**NOTE:** The rough-in dimensions listed on this drawing are based on current information available to Jay R. Smith by the fixture manufacturers. We recommend that you verify these dimensions with the fixture manufacturer. We will not accept responsibility for rough-in dimension changes by the fixture manufacturer.

**NOTE:** Dimensions shown in parentheses are in millimeters.

**0790**

DRAWING NUMBER **S0790 (B)**  
 SIZE **A**  
 SCALE: **NONE**  
 DATE: **10-18-63**  
 APPROVED BY:  
 CHECKED BY: **RP**  
 DRAWN BY: **SL**

WE CAN ASSUME NO RESPONSIBILITY FOR USE OF SUPERSEDED OR VOID DATA  
 DIMENSIONS ARE SUBJECT TO MANUFACTURERS TOLERANCE AND CHANGE WITHOUT NOTICE

REV.	DATE	DESCRIPTION	BY	CKD. BY	WEIGHT POUNDS	VOLUME CUBIC FEET	<b>FIGURE NUMBER</b> <b>0790</b>