

E



**JAY R. SMITH MFG. CO.**  
 DIVISION OF SMITH INDUSTRIES, INC.  
 POST OFFICE BOX 3237  
 MONTGOMERY, ALABAMA 36109-0237 (USA)  
 TEL: 334-277-8520 FAX: 334-272-7396 www.jrsmith.com



MEMBER OF:

LOCATION

## LAVATORY SUPPORTS WITH EXPOSED ARMS

### WALL MOUNTED WITH ACID RESISTANT COATED EXPOSED ARMS

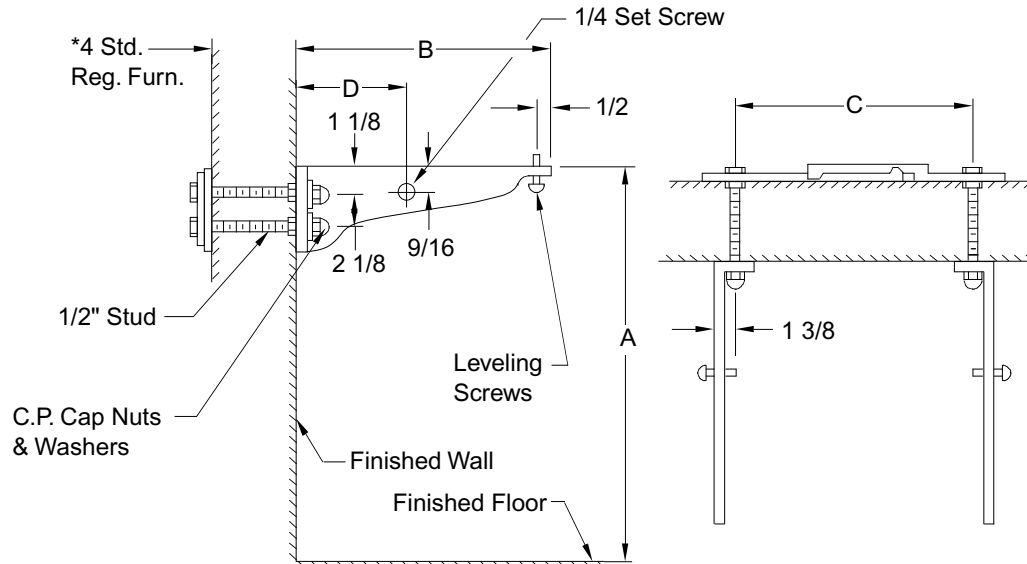

Fig. 0782 . . . WITH OFFSET ARMS FOR HIGH BACK ENAMELED IRON LAVATORIES SET ON BLOCK WALL

\* This dimension can be increased when required (specify wall thickness)

#### ROUGHING-IN TABLE

| FIXTURE MFG. | NAME    | NUMBER    | SIZE    | A      | B  | C      | D     |
|--------------|---------|-----------|---------|--------|----|--------|-------|
| AM. STD.     | REGALYN | 4867.016  | 19 x 17 | 30 5/8 | 11 | 14 1/8 | 8     |
| AM. STD.     | REGALYN | 4867.024  | 20 x 18 | 30 5/8 | 15 | 15 1/8 | 8     |
| AM. STD.     | REGALYN | 4869.012  | 19 x 17 | 30 5/8 | 11 | 14 1/8 | 8     |
| AM. STD.     | REGALYN | 4869.020  | 20 x 18 | 30 5/8 | 15 | 15 1/8 | 8     |
| CRANE        | FERMONT | 1-506     | 19 x 17 | 30 3/4 | 11 | 14 1/4 | 9     |
| CRANE        | FERMONT | 1-506     | 20 x 18 | 30 3/4 | 15 | 15 1/4 | 11    |
| KOHLER       | HAMPTON | K-2705    | 19 x 17 | 30 7/8 | 11 | 13 1/4 | 8     |
| KOHLER       | HAMPTON | K-2705    | 22 x 19 | 30 3/4 | 15 | 14 3/4 | 10    |
| KOHLER       | DELTON  | K-2736, 7 | 18 x 15 | 30 3/4 | 11 | 12 7/8 | 9 1/2 |
| KOHLER       | CHESTER | K-2792    | 19 x 17 | 30 3/4 | 11 | 12 7/8 | 8     |
| KOHLER       | HUDSON  | K-2861, 3 | 19 x 17 | 30 1/2 | 11 | 13 1/2 | 9     |
| KOHLER       | HUDSON  | K-2861, 3 | 20 x 18 | 30 3/4 | 15 | 14     | 9     |

**NOTE:** The rough-in dimensions listed on this drawing are based on current information available to Jay R. Smith by the fixture manufacturers. We recommend that you verify these dimensions with the fixture manufacturer. We will not accept responsibility for rough-in dimension changes by the fixture manufacturer.

DRAWING NUMBER  
S0782SIZE  
ASCALE:  
NONEDATE:  
4-28-65

APPROVED BY:

CHECKED BY:  
RPDRAWN BY:  
SL

0782

FIGURE  
NUMBER

WE CAN ASSUME NO RESPONSIBILITY FOR USE OF SUPERSEDED OR VOID DATA

DIMENSIONS ARE SUBJECT TO MANUFACTURERS TOLERANCE AND CHANGE WITHOUT NOTICE

E

9-26-94

Submittal Update

EMB

BS

WEIGHT  
POUNDSVOLUME  
CUBIC FEET

FIGURE NUMBER

0782

REV.

DATE

DESCRIPTION

BY

CKD. BY

F



**JAY R. SMITH MFG. CO.**  
 DIVISION OF SMITH INDUSTRIES, INC.  
 POST OFFICE BOX 3237  
 MONTGOMERY, ALABAMA 36109-0237 (USA)  
 TEL: 334-277-8520 FAX: 334-272-7396 www.jrsmith.com



MEMBER OF:

LOCATION

# LAVATORY SUPPORTS WITH EXPOSED ARMS

## WALL MOUNTED WITH ACID RESISTANT COATED EXPOSED ARMS

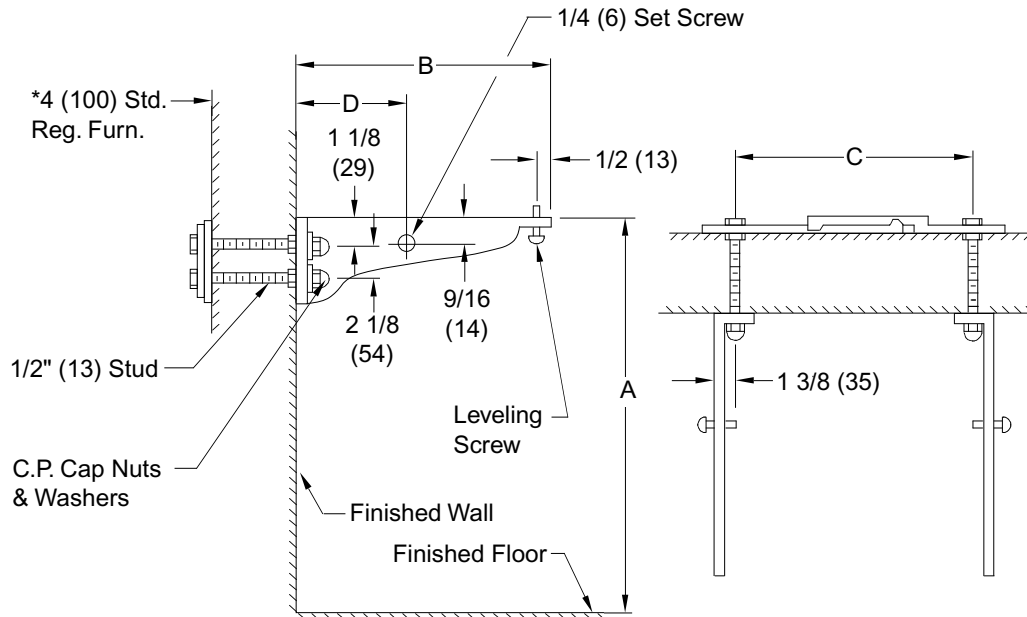

Fig. 0782 . . . WITH OFFSET ARMS FOR HIGH BACK ENAMELED IRON LAVATORIES SET ON BLOCK WALL

\* This dimension can be increased when required (specify wall thickness)

### ROUGHING-IN TABLE

| FIXTURE NAME | NUMBER | SIZE | A | B | C | D |
|--------------|--------|------|---|---|---|---|
|              |        |      |   |   |   |   |

**NOTE:** The rough-in dimensions listed on this drawing are based on current information available to Jay R. Smith by the fixture manufacturers. We recommend that you verify these dimensions with the fixture manufacturer. We will not accept responsibility for rough-in dimension changes by the fixture manufacturer.

**NOTE:** Dimensions shown in parentheses are in millimeters.

DRAWING NUMBER  
S0782 (B)

SIZE  
A

SCALE:  
NONE

DATE:  
4-28-65

APPROVED BY:

CHECKED BY:  
RP

DRAWN BY:  
SL

0782

WE CAN ASSUME NO RESPONSIBILITY FOR USE OF SUPERSEDED OR VOID DATA

DIMENSIONS ARE SUBJECT TO MANUFACTURERS TOLERANCE AND CHANGE WITHOUT NOTICE

|      |         |                   |     |         |                  |                      |                              |
|------|---------|-------------------|-----|---------|------------------|----------------------|------------------------------|
| F    | 4-2-97  | Added Millimeters | EMB | BS      | WEIGHT<br>POUNDS | VOLUME<br>CUBIC FEET | FIGURE NUMBER<br><b>0782</b> |
| E    | 8-12-93 | Submittal Update  | EMB | BS      |                  |                      |                              |
| REV. | DATE    | DESCRIPTION       | BY  | CKD. BY |                  |                      |                              |