

LAVATORY SUPPORTS WITH EXPOSED ARMS

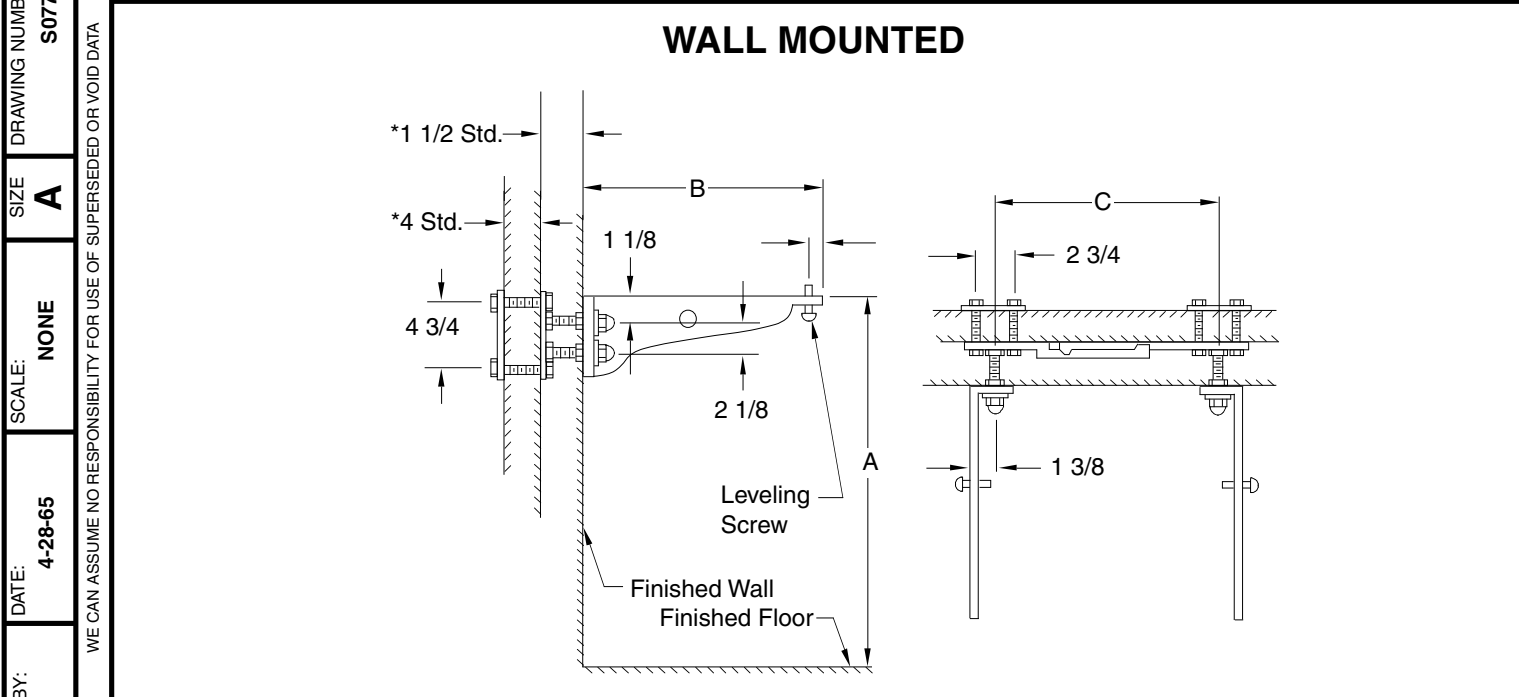

Fig. 0772 . . . WITH OFFSET ACID RESISTANT COATED EXPOSED ARMS FOR HIGH BACK ENAMELED IRON LAVATORIES SET ON MASONRY OR STUD WALL

* This dimension can be increased when required (specify wall thickness).

ROUGHING-IN TABLE

FIXTURE MFG.	NAME	NUMBER	SIZE	A	B	C	D
AM. STD.	REGALYN	4867.016	19 x 17	30 5/8	11	14 1/8	8
AM. STD.	REGALYN	4867.024	20 x 18	30 5/8	15	15 1/8	8
AM. STD.	REGALYN	4869.012	19 x 17	30 5/8	11	14 1/8	8
AM. STD.	REGALYN	4869.020	20 x 18	30 5/8	15	15 1/8	8
CRANE	FERMONT	1-506	19 x 17	30 3/4	11	14 1/4	9
CRANE	FERMONT	1-506	20 x 18	30 3/4	15	15 1/4	11
KOHLER	HAMPTON	K-2705	19 x 17	30 7/8	11	13 1/4	8
KOHLER	HAMPTON	K-2705	22 x 19	30 3/4	15	14 3/4	10
KOHLER	DELTON	K-2736, 7	18 x 15	30 3/4	11	12 7/8	9 1/2
KOHLER	CHESTER	K-2792	19 x 17	30 3/4	11	12 7/8	8
KOHLER	HUDSON	K-2861, 3	19 x 17	30 1/2	11	13 1/2	9
KOHLER	HUDSON	K-2861, 3	20 x 18	30 3/4	15	14	9

NOTE: The rough-in dimensions listed on this drawing are based on current information available to Jay R. Smith by the fixture manufacturers. We recommend that you verify these dimensions with the fixture manufacturer. We will not accept responsibility for rough-in dimension changes by the fixture manufacturer.

DRAWING NUMBER **S0772**
 SIZE **A**
 SCALE: **NONE**
 DATE: **4-28-65**
 APPROVED BY:
 CHECKED BY: **RP**
 DRAWN BY: **SL**
0772
 DIMENSIONS ARE SUBJECT TO MANUFACTURERS TOLERANCE AND CHANGE WITHOUT NOTICE

WE CAN ASSUME NO RESPONSIBILITY FOR USE OF SUPERSEDED OR VOID DATA

C	9-26-94	Submittal Update	EMB	BS	WEIGHT POUNDS	VOLUME CUBIC FEET	FIGURE NUMBER
REV.	DATE	DESCRIPTION	BY	CKD. BY			0772

LAVATORY SUPPORTS WITH EXPOSED ARMS

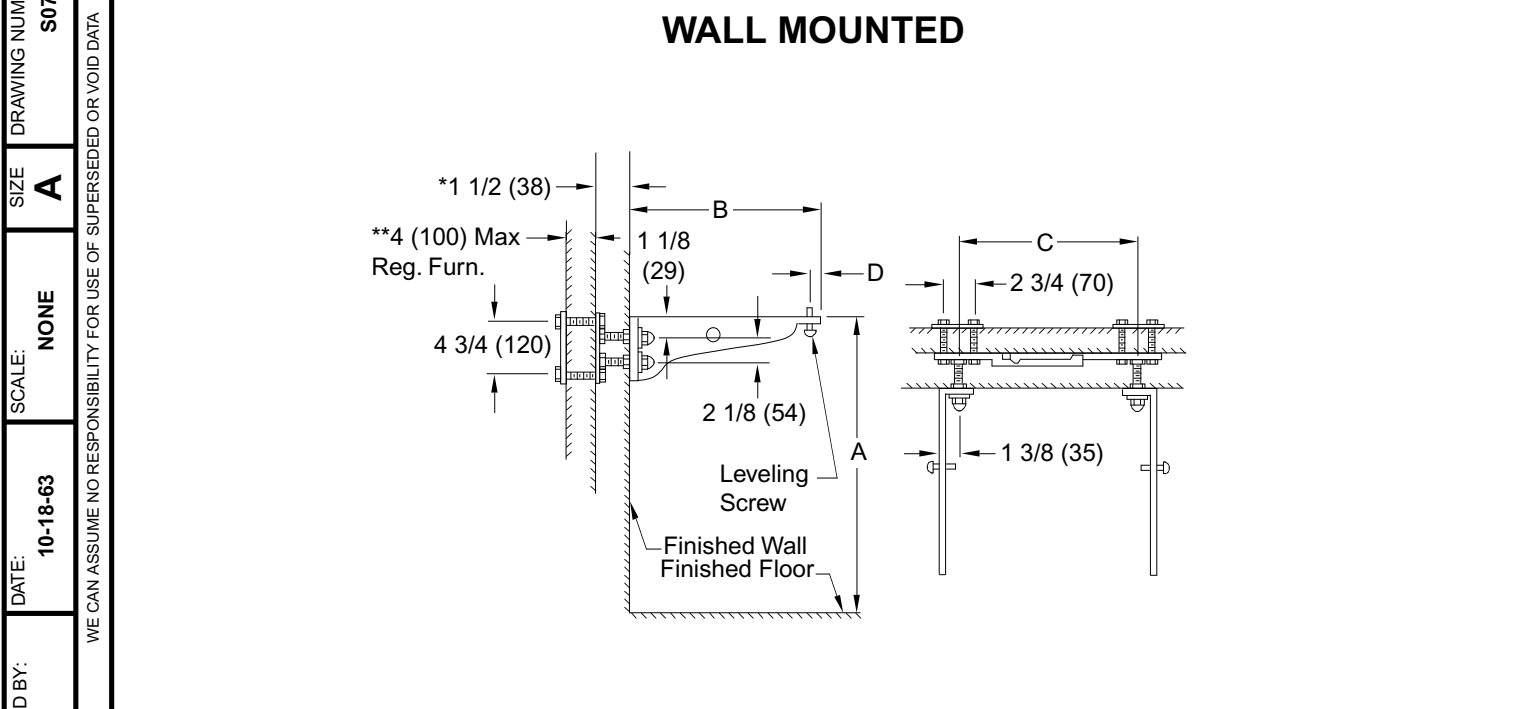

**Fig. 0772 ... WITH OFFSET ACID RESISTANT COATED EXPOSED ARMS
FOR HIGH BACK ENAMELED IRON LAVATORIES SET ON
MASONRY OR STUD WALL**

* This dimension can be increased when required (specify wall thickness).
 **For greater wall thickness, larger supporting studs can be furnished (specify wall thickness.)

ROUGHING-IN TABLE

FIXTURE NAME	NUMBER	SIZE	A	B	C	D

NOTE: Dimensions shown in parentheses are in millimeters.

NOTE: The rough-in dimensions listed on this drawing are based on current information available to Jay R. Smith by the fixture manufacturers. We recommend that you verify these dimensions with the fixture manufacturer. We will not accept responsibility for rough-in dimension changes by the fixture manufacturer.

DRAWING NUMBER: S0772 (B)
 SIZE: A
 SCALE: NONE
 DATE: 10-18-63
 APPROVED BY:
 CHECKED BY: RP
 DRAWN BY: SL
 FIGURE NUMBER: 0772
 DIMENSIONS ARE SUBJECT TO MANUFACTURERS TOLERANCE AND CHANGE WITHOUT NOTICE
 WE CAN ASSUME NO RESPONSIBILITY FOR USE OF SUPERSEDED OR VOID DATA

REV.	DATE	DESCRIPTION	BY	CKD. BY	WEIGHT POUNDS	VOLUME CUBIC FEET	FIGURE NUMBER 0772