

LAVATORY SUPPORTS WITH EXPOSED ARMS

WALL MOUNTED

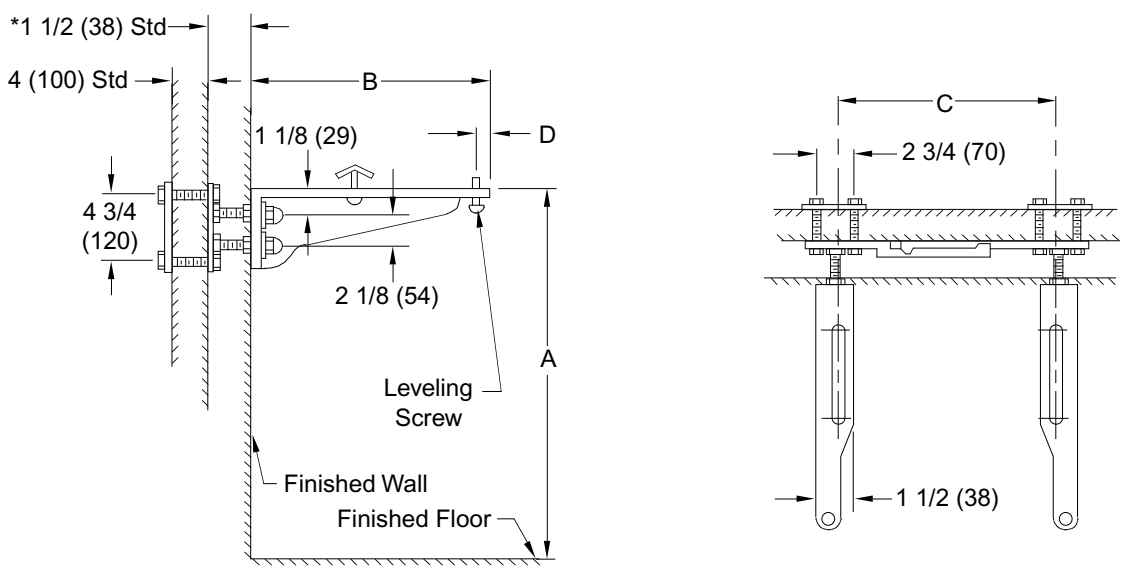

Fig. 0770 . . . WITH ACID RESISTANT COATED EXPOSED ARMS FOR FLAT SLAB AND HIGH BACK LAVATORIES SET ON MASONRY OR STUD WALL

*This dimension can be increased when required (specify wall thickness).

ROUGHING-IN TABLE

FIXTURE MFG.	NAME	NUMBER	SIZE	A	B	C	D
AM. STD.	NEW LUCERNE	0355.027	20(508) X 18(457)	27 1/2(700)	11(280)	13 3/8(340)	1/2(13)
AM. STD.	NEW LUCERNE	0356.028	20(508) X 18(457)	27 1/2(700)	11(280)	13 3/8(340)	1/2(13)
AM. STD.	ROXALYN	0194.019	20(508) X 18(457)	27 5/8(702)	15(380)	16 1/2(420)	1/2(13)
AM. STD.	ROXALYN	0194.100	24(610) X 20(508)	27 1/4(690)	18 1/2(470)	18 1/2(470)	1/2(13)
AM. STD.	ROXALYN	0195.016	20(508) X 18(457)	27 5/8(702)	15(380)	16 1/2(420)	1/2(13)
AM. STD.	ROXALYN	0195.222	24(610) X 20(508)	27 1/4(690)	18 1/2(470)	18 1/2(470)	1/2(13)
CRANE	NORWICH	1-160, 2	20(508) X 18(457)	27 5/8(702)	15(380)	16 1/4(415)	1/2(13)
CRANE	NORWICH	1-160, 2	24(610) X 21(533)	27 1/2(700)	18 1/2(470)	19 1/2(495)	1/2(13)
ELJER	MAYBURNE	051-2314,2518	20(508) X 18(457)	27(685)	15(380)	17 1/4(440)	1/2(13)
ELJER	MAYBURNE	051-2324,2528	24(610) X 20(508)	27(685)	18 1/2(470)	19 3/8(497)	1/2(13)
KOHLER	GRAMERCY	1607	19 (482)X 17(432)	27 1/4(690)	15(380)	16 1/2(420)	1/2(13)
KOHLER	GRAMERCY	1607	22(559) X 18(457)	27 1/4(690)	15(380)	19(485)	3(76)
KOHLER	JAMESTOWN	K-2047,49,51,52	20(508) X 18(457)	27 1/4(690)	15(380)	16 1/2(420)	1 1/2(38)
KOHLER	JAMESTOWN	K-2047,49,51,52	24(610) X 20(508)	27 1/4(690)	18 1/2(470)	19(485)	1 1/2(38)
U.RUNDLE	NEW CAMDEN	4648, 9	20(508) X 18(457)	28(710)	15(380)	16(405)	1/2(13)
U. RUNDLE	NEW CAMPUS	4698, 9	20(508) X 18(457)	28(710)	15(380)	16(405)	1/2(13)
KOHLER	JAMESTOWN	K-2054	20(508) X 18(457)	27 1/4(690)	15(380)	16 1/2(420)	1 1/2(38)

NOTE: The rough-in dimensions listed on this drawing are based on current information available to Jay R. Smith by the fixture manufacturers. We recommend that you verify these dimensions with the fixture manufacturer. We will not accept responsibility for rough-in dimension changes by the fixture manufacturer.

DRAWING NUMBER: S0770
 SIZE: A
 SCALE: NONE
 DATE: 1-31-75
 APPROVED BY: TD
 CHECKED BY: RS
 DRAWN BY: RAS
 FIGURE NUMBER: 0770
 DIMENSIONS ARE SUBJECT TO MANUFACTURERS TOLERANCE AND CHANGE WITHOUT NOTICE
 WE CAN ASSUME NO RESPONSIBILITY FOR USE OF SUPERSEDED OR VOID DATA

F	3-10-99	Revised Table Submittal Update	CMD	BS	WEIGHT POUNDS	VOLUME CUBIC FEET	FIGURE NUMBER 0770
E	9-26-94		EMB	BS			
REV.	DATE	DESCRIPTION	BY	CKD. BY			

LAVATORY SUPPORTS WITH EXPOSED ARMS

WALL MOUNTED

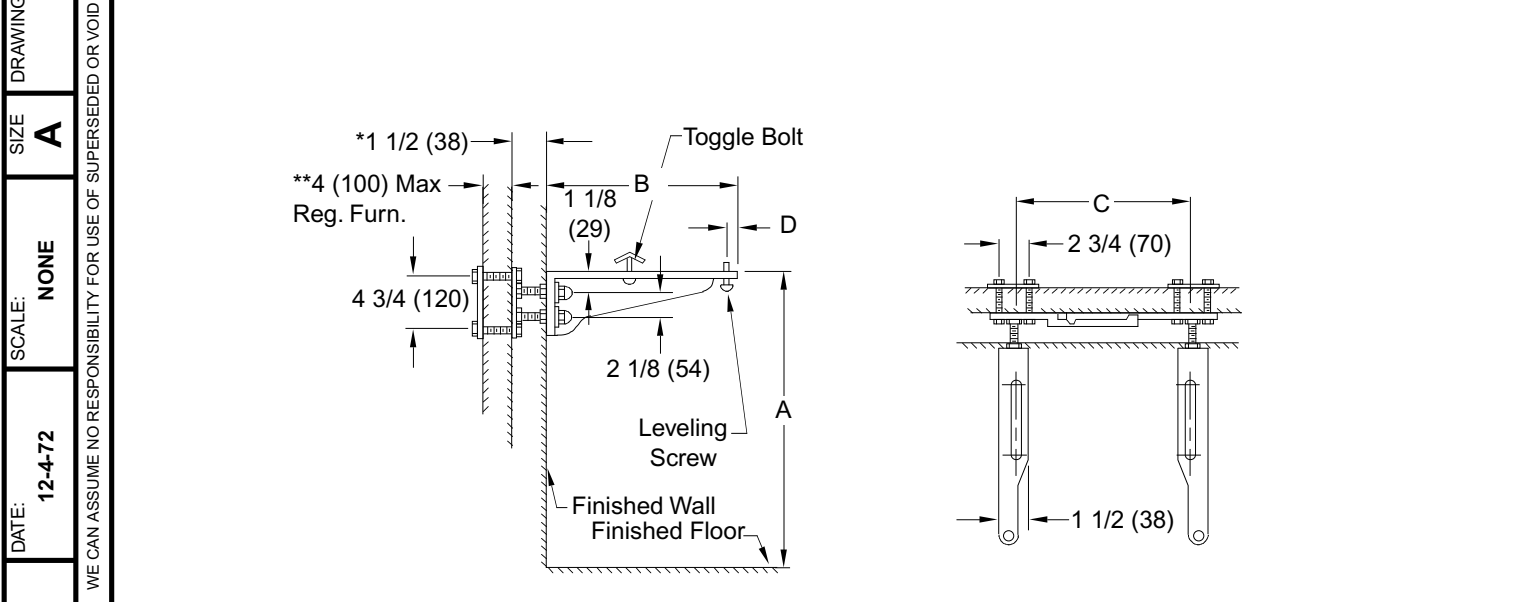

Fig. 0770 . . . WITH ACID RESISTANT COATED EXPOSED ARMS FOR FLAT SLAB AND HIGH BACK LAVATORIES SET ON MASONRY OR STUD WALL

*This dimension can be increased when required (specify wall thickness).
 **For greater wall thickness, longer supporting studs can be furnished (specify wall thickness).

ROUGHING-IN TABLE

FIXTURE NAME	NUMBER	SIZE	A	B	C	D

NOTE: The rough-in dimensions listed on this drawing are based on current information available to Jay R. Smith by the fixture manufacturers. We recommend that you verify these dimensions with the fixture manufacturer. We will not accept responsibility for rough-in dimension changes by the fixture manufacturer.

NOTE: Dimensions shown in parentheses are in millimeters.

0770

DRAWING NUMBER: **S0770 (B)** SIZE: **A** SCALE: **NONE** DATE: **12-4-72** APPROVED BY: CHECKED BY: **RP** DRAWN BY: **BS**

WE CAN ASSUME NO RESPONSIBILITY FOR USE OF SUPERSEDED OR VOID DATA

DIMENSIONS ARE SUBJECT TO MANUFACTURERS TOLERANCE AND CHANGE WITHOUT NOTICE

FIGURE NUMBER

C	4-2-97 8-10-93	Added Millimeters Submittal Update	EMB EMB	BS BS	WEIGHT POUNDS	VOLUME CUBIC FEET	FIGURE NUMBER
REV.	DATE	DESCRIPTION	BY	CKD. BY			0770