

LAVATORY SUPPORTS WITH EXPOSED ARMS

FLOOR MOUNTED WITH "PRO-SET" UPRIGHTS

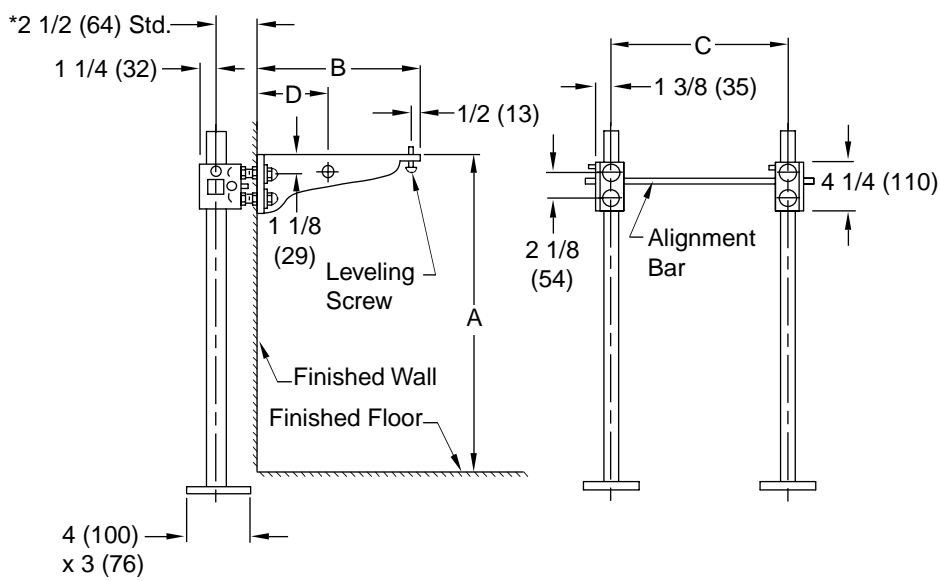
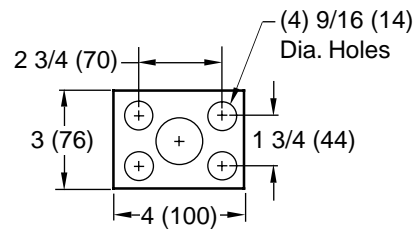

Fig. 0752 . . . WITH OFFSET ARMS FOR HIGH BACK ENAMELED IRON LAVATORIES

*This dimension can be increased when fixture support is to be installed behind the wall (specify when required and wall thickness).

NOTE: For metal stud wall construction, specify Suffix -M31 rectangular steel upright with welded base for greater strength.

NOTE: Dimensions shown in parentheses are in millimeters.



BASE DETAIL

ROUGHING-IN TABLE

FIXTURE NAME	NUMBER	SIZE	A	B	C	D

NOTE: The rough-in dimensions listed on this drawing are based on current information available to Jay R. Smith by the fixture manufacturers. We recommend that you verify these dimensions with the fixture manufacturer. We will not accept responsibility for rough-in dimension changes by the fixture manufacturer.

DRAWING NUMBER: **S0752 (B)**
 SIZE: **A**
 SCALE: **NONE**
 DATE: **10-18-63**
 APPROVED BY: **RP**
 CHECKED BY: **SL**
 DRAWN BY: **SL**
0752
 FIGURE NUMBER

WE CAN ASSUME NO RESPONSIBILITY FOR USE OF SUPERSEDED OR VOID DATA
 DIMENSIONS ARE SUBJECT TO MANUFACTURERS TOLERANCE AND CHANGE WITHOUT NOTICE

E	01/19/00	Revised Base Plate	JJ	WEIGHT	VOLUME	FIGURE NUMBER
D	6-12-95	Added Millimeters	EMB	POUNDS	CUBIC FEET	0752
C	3-21-94	Added Dim	EMB			
B	8-10-93	Submittal Update	BS			
REV.	DATE	DESCRIPTION	BY	CKD. BY		