

C

SMITH® JAY R. SMITH MFG. CO.®
 DIVISION OF SMITH INDUSTRIES, INC.
 POST OFFICE BOX 3237
 MONTGOMERY, ALABAMA 36109-0237 (USA)
 TEL: 334-277-8520 FAX: 334-272-7396 www.jrsmith.com



MEMBER OF:

LOCATION

LAVATORY SUPPORTS WITH CONCEALED ARMS

WALL MOUNTED

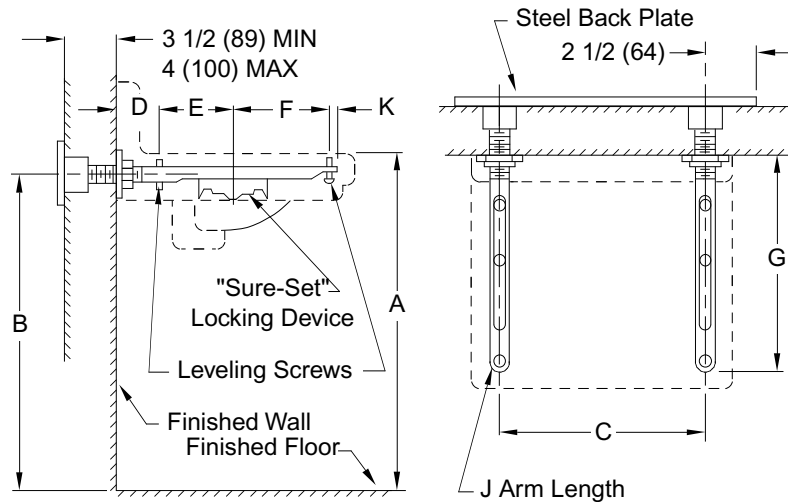

Fig. 0728 . . . FOR HIGH BACK LAVATORIES SET ON STEEL PLATE SECURED TO BLOCK WALL

ROUGHING-IN TABLE

FIXTURE NAME				NUMBER			SIZE	
A	B	C	D	E	F	G	J	K

NOTE: The rough-in dimensions listed on this drawing are based on current information available to Jay R. Smith by the fixture manufacturers. We recommend that you verify these dimensions with the fixture manufacturer. We will not accept responsibility for rough-in dimension changes by the fixture manufacturer.

NOTE: Dimensions shown in parentheses are in millimeters.

DRAWING NUMBER
S0728 (B)

SIZE
A

SCALE:
NONE

DATE:
10-9-69

APPROVED BY:

CHECKED BY:
BH

DRAWN BY:
RVB

0728

WE CAN ASSUME NO RESPONSIBILITY FOR USE OF SUPERSEDED OR VOID DATA

DIMENSIONS ARE SUBJECT TO MANUFACTURERS TOLERANCE AND CHANGE WITHOUT NOTICE

C	4-2-97	Added Millimeters	EMB	BS
B	8-10-93	Submittal Update	EMB	BS
REV.	DATE	DESCRIPTION	BY	CKD. BY

WEIGHT POUNDS	VOLUME CUBIC FEET

FIGURE NUMBER
0728