

F

SMITH® JAY R. SMITH MFG. CO.®
 DIVISION OF SMITH INDUSTRIES, INC.
 POST OFFICE BOX 3237
 MONTGOMERY, ALABAMA 36109-0237 (USA)
 TEL: 334-277-8520 FAX: 334-272-7396 www.jrsmith.com



LOCATION

LABOR SAVER® LAVATORY SUPPORTS

FLOOR MOUNTED TYPE WITH CONCEALED ARMS

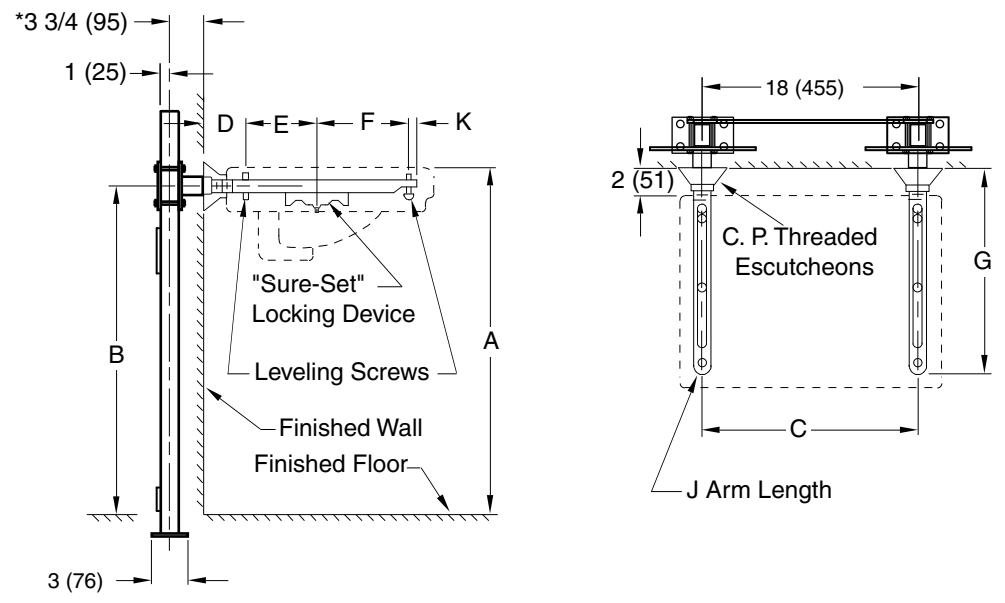
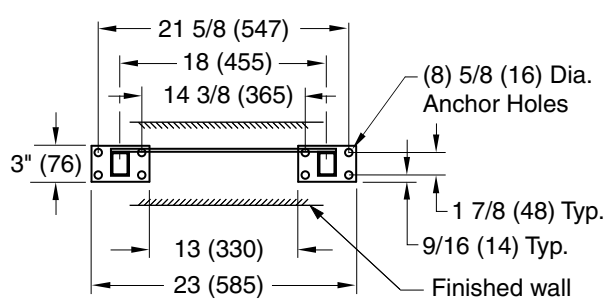

Fig. 0710 (-E) . . . FOR FLAT SLAB LAVATORIES (shown)

NOTE: The rough-in dimensions listed on this drawing are based on current information available to Jay R. Smith by the fixture manufacturers. We recommend that you verify these dimensions with the fixture manufacturer. We will not accept responsibility for rough-in dimension changes by the fixture manufacturer.

NOTE: *This dimension can be increased when fixture support is to be installed behind the wall. (Specify when required and wall thickness).

NOTE: Dimensions shown in parentheses are in millimeters.



BASE DETAIL

ROUGH-IN TABLE

FIXTURE MFG.		NAME		NUMBER		SIZE		
A	B	C	D	E	F	G	J	K

DRAWING NUMBER S0710 (-E)
 SIZE A
 SCALE: NONE
 DATE: 06/26/01
 APPROVED BY: AM
 CHECKED BY: CR
 DRAWN BY: JJ
0710 (-E)
 DIMENSIONS ARE SUBJECT TO MANUFACTURERS TOLERANCE AND CHANGE WITHOUT NOTICE

WE CAN ASSUME NO RESPONSIBILITY FOR USE OF SUPERSEDED OR VOID DATA

REV.	DATE	DESCRIPTION	BY	CKD. BY	WEIGHT POUNDS	VOLUME CUBIC FEET	FIGURE NUMBER
D E D	07/23/08 11/07/02 08/02/02	Revised Plate Configuration Changed per George Flegel Removed unnecessary dimension	JJ JJ JJ	CL AM AM			0710 (-E)