

LABOR SAVER® LAVATORY SUPPORT FLOOR MOUNTED WITH CONCEALED ARMS

FOR FLAT SLAB WHEELCHAIR PATIENTS LAVATORY

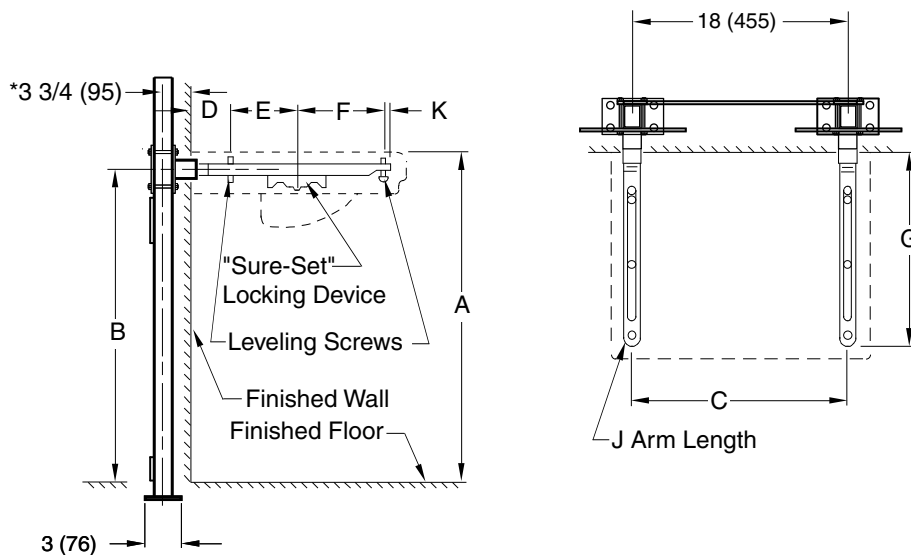
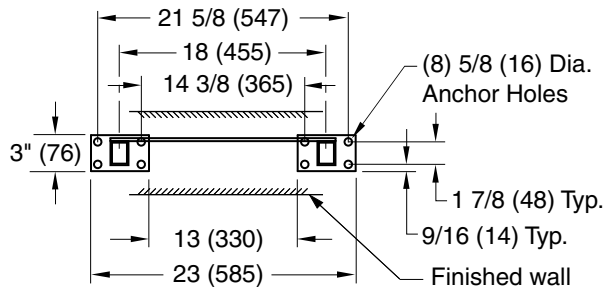

Fig. 0710 (-27) ... FOR HIGH BACK LAVATORIES (shown)

NOTE: The rough-in dimensions listed on this drawing are based on current information available to Jay R. Smith by the fixture manufacturers. We recommend that you verify these dimensions with the fixture manufacturer. We will not accept responsibility for rough-in dimension changes by the fixture manufacturer.

NOTE: *This dimension includes a wall thickness of 1/2". For greater wall thickness, specify centerline of upright to finished wall dimension.

NOTE: Dimensions shown in parentheses are in millimeters.



BASE DETAIL

ROUGHING-IN TABLE

FIXTURE MFG.		NAME		NUMBER		SIZE		
A	B	C	D	E	F	G	J	K

D	07/22/08	Revised Plate Configuration	JJ	CL	WEIGHT POUNDS	VOLUME CUBIC FEET	FIGURE NUMBER 0710 (-27)
C	12/09/02	Revised per George Flegel	JJ	AM			
B	7/16/02	Changed Fig. 0700 to 0710	RN	AM			
A	12/19/01	Changed Hole Size in Base	JJ	AM			
REV.	DATE	DESCRIPTION	BY	CKD. BY			

DRAWING NUMBER
S0710 (-27)

SIZE
A

SCALE:
NONE

DATE:
07/11/01

APPROVED BY:
AM

CHECKED BY:
CR

DRAWN BY:
JJ

0710 (-27)

WE CAN ASSUME NO RESPONSIBILITY FOR USE OF SUPERSEDED OR VOID DATA

DIMENSIONS ARE SUBJECT TO MANUFACTURERS TOLERANCE AND CHANGE WITHOUT NOTICE

FIGURE NUMBER