

C



**JAY R. SMITH MFG. CO.**  
 DIVISION OF SMITH INDUSTRIES, INC.  
 POST OFFICE BOX 3237  
 MONTGOMERY, ALABAMA 36109-0237 (USA)  
 TEL: 334-277-8520 FAX: 334-272-7396 www.jrsmith.com



MEMBER OF:

LOCATION

# LAVATORY SUPPORTS WITH CONCEALED ARMS

## FLOOR MOUNTED TYPE WITH "PRO-SET" UPRIGHTS

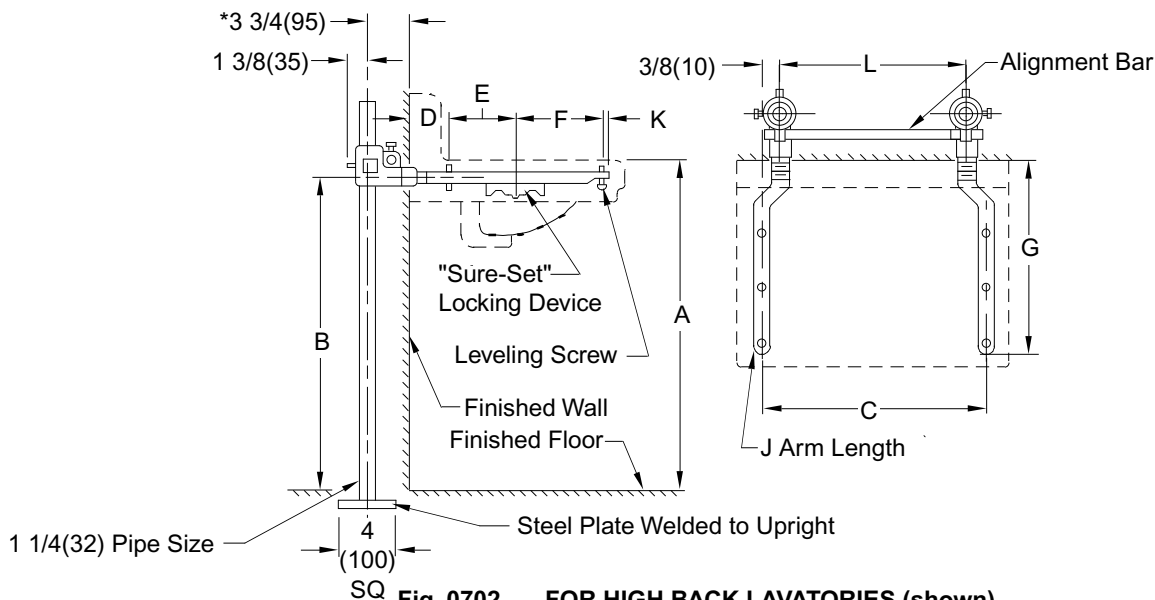
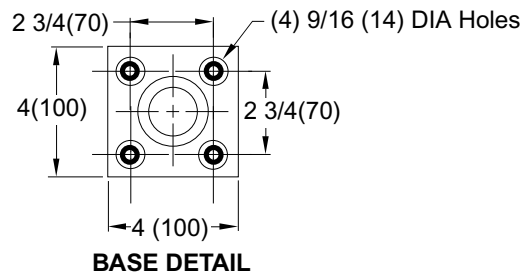

Fig. 0702 ... FOR HIGH BACK LAVATORIES (shown)

**NOTE:** The rough-in dimensions listed on this drawing are based on current information available to Jay R. Smith by the fixture manufacturers. We recommend that you verify these dimensions with the fixture manufacturer. We will not accept responsibility for rough-in dimension changes by the fixture manufacturer.



### ROUGHING-IN TABLE

FIXTURE NAME				NUMBER				SIZE		
A	B	C	D	E	F	G	J	K	L	

**NOTE:** \*This dimension can be increased when fixture support is to be installed behind the wall. (Specify when required and wall thickness).

DRAWING NUMBER  
S0702 (B)

SIZE  
A

SCALE:  
NONE

DATE:  
4-8-85

APPROVED BY:  
RP

CHECKED BY:  
TD

DRAWN BY:  
WZ

0702

FIGURE NUMBER

WE CAN ASSUME NO RESPONSIBILITY FOR USE OF SUPERSEDED OR VOID DATA

DIMENSIONS ARE SUBJECT TO MANUFACTURERS TOLERANCE AND CHANGE WITHOUT NOTICE

C	10-7-98	Added Note Submittal Update	CMD	BS
B	10-10-94		EMB	
REV.	DATE	DESCRIPTION	BY	CKD. BY

WEIGHT POUNDS	VOLUME CUBIC FEET

FIGURE NUMBER  
**0702**