

LAVATORY SUPPORTS WITH CONCEALED ARMS

FLOOR MOUNTED WITH RECTANGULAR 1(25) X 3(76) "PRO-SET" UPRIGHTS

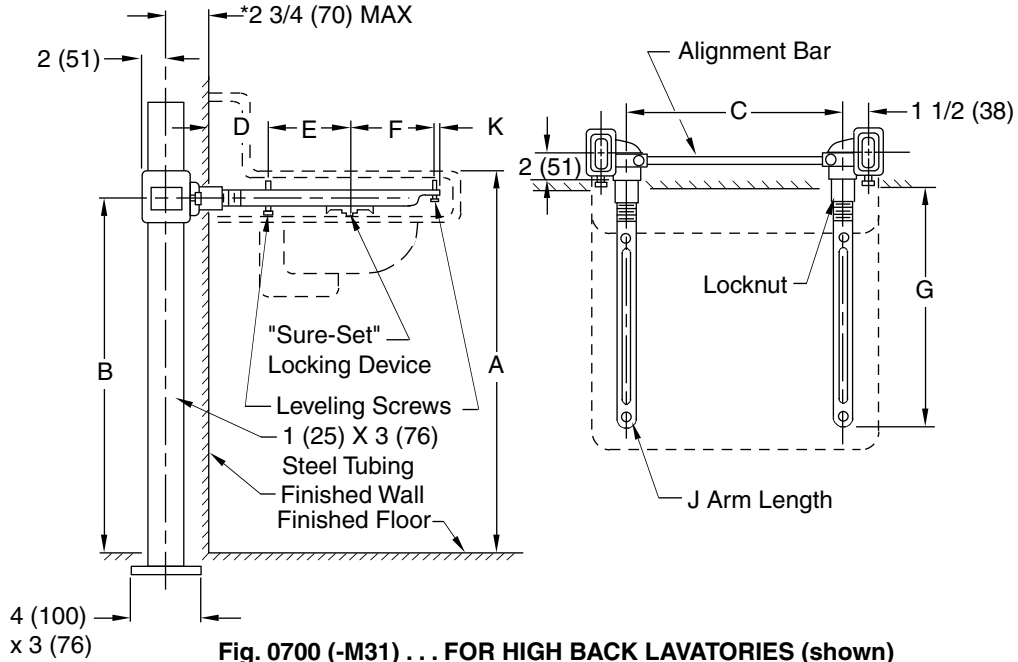
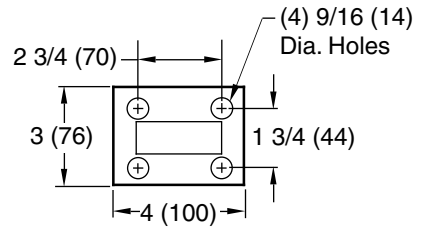

Fig. 0700 (-M31) . . . FOR HIGH BACK LAVATORIES (shown)

NOTE: The rough-in dimensions listed on this drawing are based on current information available to Jay R. Smith by the fixture manufacturers. We recommend that you verify these dimensions with the fixture manufacturer. We will not accept responsibility for rough-in dimension changes by the fixture manufacturer.



BASE DETAIL

NOTE: Dimensions shown in parentheses are in millimeters.

NOTE: Front leveling screws should protrude 1" (25) above arms.

ROUGHING-IN TABLE

FIXTURE NAME				NUMBER			SIZE	
A	B	C	D	E	F	G	J	K

*This dimension includes wall thickness of 1/2" (13). For greater wall thickness, specify centerline of upright to finished wall dimension.

0700 (-M31)

DRAWING NUMBER S0700 (-M31) (B) SIZE A SCALE: NONE DATE: 2-2-70 APPROVED BY: AB CHECKED BY: RLK DRAWN BY: AB

WE CAN ASSUME NO RESPONSIBILITY FOR USE OF SUPERSEDED OR VOID DATA DIMENSIONS ARE SUBJECT TO MANUFACTURERS TOLERANCE AND CHANGE WITHOUT NOTICE

G F E	01/08/08 1-31-97 6-12-95	Revised Base Plate Added dimensions Added Millimeters	JJ CMD EMB	BS BS BS	WEIGHT POUNDS	VOLUME CUBIC FEET	FIGURE NUMBER 0700 (-M31)
REV.	DATE	DESCRIPTION	BY	CKD. BY			