

G

**JAY R. SMITH MFG. CO.®**

 DIVISION OF SMITH INDUSTRIES, INC.  
 POST OFFICE BOX 3237  
 MONTGOMERY, ALABAMA 36109-0237 (USA)  
 TEL: 334-277-8520 FAX: 334-272-7396 www.jrsmith.com

MEMBER OF:



LOCATION

DRAWING NUMBER  
S0700D (-E)SIZE  
ASCALE:  
NONEDATE:  
12-12-74

APPROVED BY:

CHECKED BY:  
RSDRAWN BY:  
RAS

0700D (-E)

FIGURE  
NUMBER

WE CAN ASSUME NO RESPONSIBILITY FOR USE OF SUPERSEDED OR VOID DATA

DIMENSIONS ARE SUBJECT TO MANUFACTURERS TOLERANCE AND CHANGE WITHOUT NOTICE

## DOUBLE FIXTURE SUPPORT FLOOR MOUNTED WITH CONCEALED ARMS

### AND ESCUTCHEONS FOR FLAT SLAB LAVATORIES

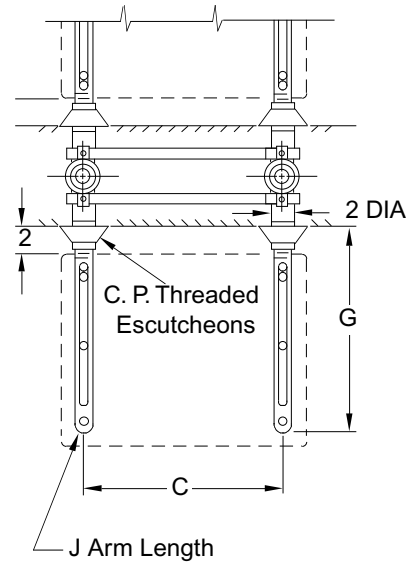
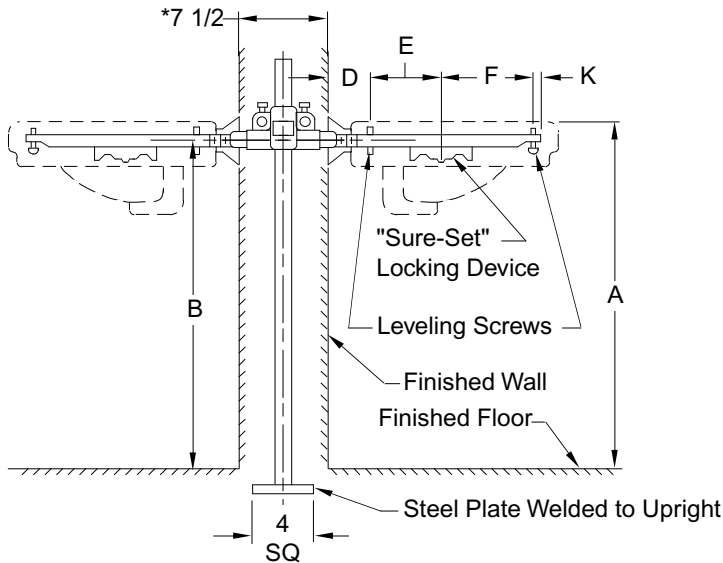
**Fig. 0700D (-E) ... FOR FLAT SLAB LAVATORIES (shown)**

**NOTE:** The rough-in dimensions listed on this drawing are based on current information available to Jay R. Smith by the fixture manufacturers. We recommend that you verify these dimensions with the fixture manufacturer. We will not accept responsibility for rough-in dimension changes by the fixture manufacturer.

**NOTE:** \* This dimension can be increased when required. (Specify wall thickness).

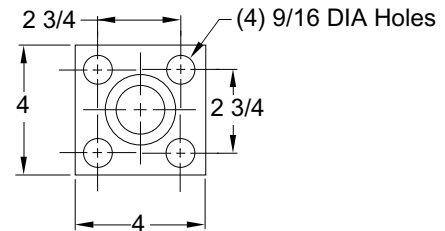
**BASE DETAIL**

#### ROUGHING-IN TABLE

FIXTURE MFG.	NAME	NUMBER	SIZE	A	B	C	D	E	F	G	J	K
AM. STD.	ROXALYN	0194.076	20 x 18	31	29 1/4	16 1/2	4	7	7	18 1/2	20	1/2
AM. STD.	ROXALYN	0194.134	24 x 20	31	29 1/4	20	4	7	7	18 1/2	20	1/2
AM. STD.	ROXALYN	0195.073	20 x 18	31	29 1/4	16 1/2	4	7	7	18 1/2	20	1/2
AM. STD.	ROXALYN	0195.289	24 x 20	31	29 1/4	20	4	7	7	18 1/2	20	1/2
CRANE	NORWICH	1-165	20 x 18	31	29 1/8	16 1/4	4	5 5/8	6 3/8	18 1/2	20	2 1/2
CRANE	NORWICH	1-165	24 x 21	31	29 1/8	19 1/2	4	5 5/8	7 1/8	18 1/4	20	1 1/2
ELJER	MAYBURNE	051-2344, 2548	20 x 18	31	29	17	4	5 5/8	5 5/8	17 1/4	19	2
ELJER	MAYBURNE	051-2354, 2558	24 x 20	31	29	20 7/8	4	5 5/8	7 1/8	18 1/4	20	1 1/2
KOHLER	JAMESTOWN	K-2053, 4, 5, 6	24 x 18	31	29	16 1/2	4	5 5/8	5 5/8	17 1/4	19	2
KOHLER	JAMESTON	K-2053, 4, 5, 6	24 x 20	31	29	19	4	7	7	18 1/2	20	1/2
U. RUNDLE	NEW CAMPUS	4698, 9	20 x 18	31	29 3/8	16 1/4	4	5	4	14	16	1

G  
T  
E9-21-94  
3-17-80  
12-12-74
 Submittal Update  
 Weld Base replace Cast Base  
 New Dwg
EMB  
TB  
RAS

CL

WEIGHT  
POUNDSVOLUME  
CUBIC FEET

FIGURE NUMBER

0700D (-E)

REV.

DATE

DESCRIPTION

BY

CKD. BY

## LAVATORY SUPPORTS WITH CONCEALED ARMS

### FLOOR MOUNTED WITH "PRO-SET" UPRIGHTS

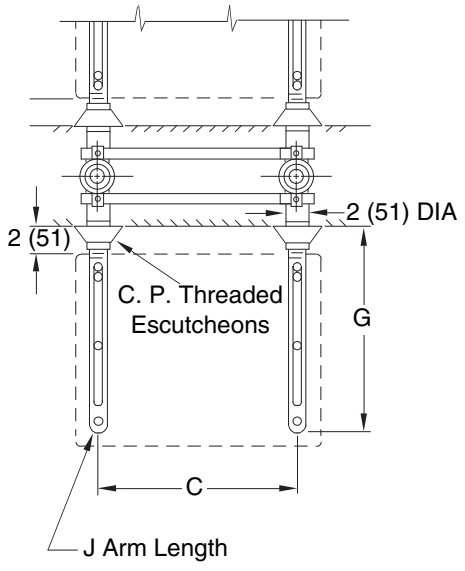
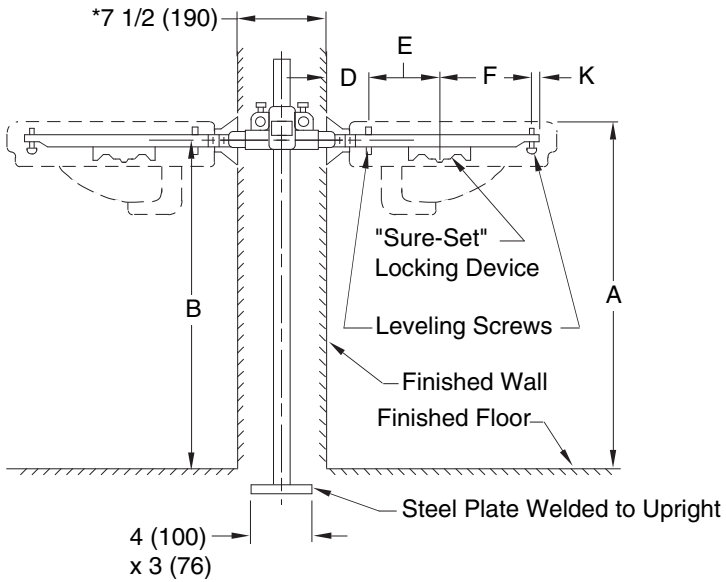
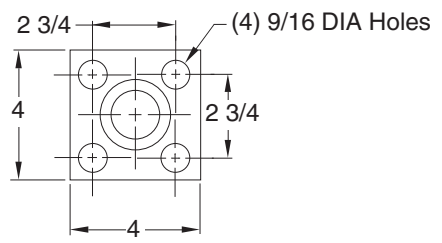

**Fig. 0700D (-E) . . . FOR FLAT SLAB LAVATORIES (shown)**

**NOTE:** Dimensions shown in parentheses are in millimeters.

**NOTE:** The rough-in dimensions listed on this drawing are based on current information available to Jay R. Smith by the fixture manufacturers. We recommend that you verify these dimensions with the fixture manufacturer. We will not accept responsibility for rough-in dimension changes by the fixture manufacturer.

**NOTE:** \* This dimension can be increased when required. (Specify wall thickness).



**BASE DETAIL**

**ROUGHING-IN TABLE**

FIXTURE NAME				NUMBER			SIZE	
A	B	C	D	E	F	G	J	K

DRAWING NUMBER: S0700D (-E) (B)  
 SIZE: A  
 SCALE: NONE  
 DATE: 12-12-74  
 APPROVED BY:  
 CHECKED BY: RS  
 DRAWN BY: RAS  
**0700D (-E)**  
 FIGURE NUMBER

WE CAN ASSUME NO RESPONSIBILITY FOR USE OF SUPERSEDED OR VOID DATA  
 DIMENSIONS ARE SUBJECT TO MANUFACTURERS TOLERANCE AND CHANGE WITHOUT NOTICE

H G	4-1-97 9-21-94	Added Millimeters Submittal Update	EMB EMB	BS BS	WEIGHT POUNDS	VOLUME CUBIC FEET	<b>FIGURE NUMBER</b> <b>0700D (-E)</b>
REV.	DATE	DESCRIPTION	BY	CKD. BY			