

M
DRAWING NUMBER S0700D
SIZE A
SCALE: NONE
DATE: 1-22-73
APPROVED BY:
CHECKED BY: RP
DRAWN BY: JH
0700D
FIGURE NUMBER



JAY R. SMITH MFG. CO.®
DIVISION OF SMITH INDUSTRIES, INC.
POST OFFICE BOX 3237
MONTGOMERY, ALABAMA 36109-0237 (USA)
TEL: 334-277-8520 FAX: 334-272-7396 www.jrsmith.com



MEMBER OF:

LOCATION

LAVATORY SUPPORTS WITH CONCEALED ARMS

FLOOR MOUNTED WITH "PRO-SET" UPRIGHTS

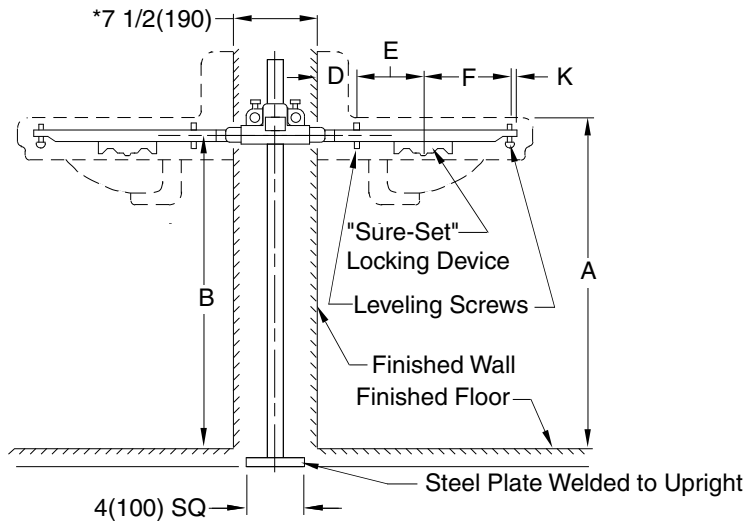
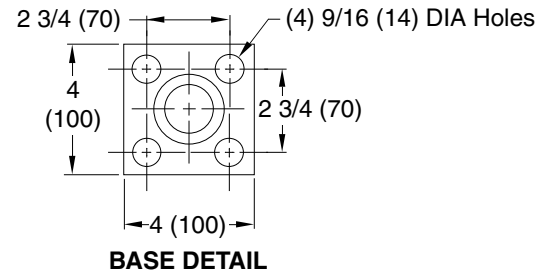
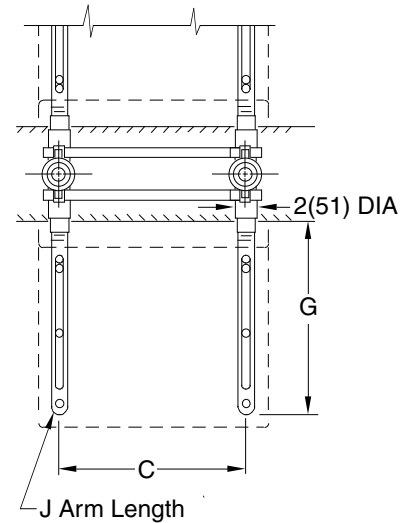

Fig. 0700D . . . FOR BACK TO BACK SUPPORT

NOTE: The rough-in dimensions listed on this drawing are based on current information available to Jay R. Smith by the fixture manufacturers. We recommend that you verify these dimensions with the fixture manufacturer. We will not accept responsibility for rough-in dimension changes by the fixture manufacturer.

NOTE: *This dimension can be increased when required (specify wall thickness).



ROUGHING-IN TABLE

FIXTURE MFG.	NAME	NUMBER	SIZE	A	B	C	D	E	F	G	J	K
AM. STD.	LUCERNE	0350.132	20(510) x 18(455)	31(785)	29 1/4(745)	16 3/4(425)	4(100)	6(150)	6(150)	16 1/2(420)	19(485)	1/2(13)
AM. STD.	LUCERNE	0350.603	24(610) x 20(510)	31(785)	29 1/4(745)	20 1/4(515)	4(100)	7(180)	7(180)	18 1/2(470)	20(510)	1/2(13)
AM. STD.	LUCERNE	0351.072	20(510) x 18(455)	31(785)	29 1/4(745)	16 3/4(425)	4(100)	6(150)	6(150)	16 1/2(420)	19(485)	1/2(13)
AM. STD.	LUCERNE	0351.247	24(610) x 20(510)	31(785)	29 1/4(745)	20 1/4(515)	4(100)	7(180)	7(180)	18 1/2(470)	20(510)	1/2(13)
CRANE	NORWICH	1-194	20(510) x 18(455)	31(785)	29 3/8(746)	16 1/4(415)	4(100)	5 5/8(143)	4 3/8(111)	14 1/2(370)	16(405)	1/2(13)
CRANE	NORWICH	1-194	24(610) x 21(535)	31(785)	29 3/8(746)	19 1/2(495)	4(100)	5 5/8(143)	7 1/8(181)	17 1/4(440)	19(485)	1/2(13)
ELJER	DELWYN	051-1634, 1838	18 (455) x 15 (380)	31 (785)	29 1/4 (745)	15 1/2 (395)	3 (76)	5 (125)	4 3/4 (120)	13 1/2 (345)	17M (430)	3/4 (19)
ELJER	SIGNATURE	051-2101, 4, 8	20 (510) x 18 (455)	34 (865)	32 (815)	17 (430)	4 (100)	5 5/8 (143)	5 5/8 (143)	15 3/4 (400)	18 (455)	1/2 (13)
KOHLER	GREENWICH	K-2030, 1, 2, 4, 6	20(510) x 18(455)	31(785)	29(735)	17 1/4(440)	3 1/4(83)	5 1/4(135)	5 1/4(135)	14 1/4(360)	16(405)	1/2(13)
KOHLER	GREENWICH	K-2030, 1, 2, 4, 6	24(610) x 20(510)	31(785)	29(735)	19(485)	3 1/4(83)	5 3/4(145)	6 1/4(160)	16 3/4(425)	19(485)	1 1/2(38)
U. RUNDLE	NEW CAMDEN	4648, 9	20(510) x 18(455)	31(785)	29 3/8(746)	16 1/4(415)	4 1/2(115)	2 1/2(64)	4(100)	13 1/2(345)	16(405)	2 1/2(64)

NOTE: All support bases must be securely anchored to a rigid floor and/or other rigid substructure with (4) 1/2" bolts furnished by others.

NOTE: Dimensions shown in parentheses are in millimeters.

M L K	04/22/09 03/19/04 03/06/02	Added Note Revised Roughing-in Table Revised Roughing-in Table	JJ JJ JJ	AM CL CL
REV.	DATE	DESCRIPTION	BY	CKD. BY

WEIGHT POUNDS	VOLUME CUBIC FEET	FIGURE NUMBER 0700D
------------------	----------------------	-------------------------------

WE CAN ASSUME NO RESPONSIBILITY FOR USE OF SUPERSEDED OR VOID DATA
DIMENSIONS ARE SUBJECT TO MANUFACTURERS TOLERANCE AND CHANGE WITHOUT NOTICE

INSTALLATION INSTRUCTIONS FOR CONCEALED ARM CARRIERS

BEFORE starting rough-in be certain you:

- know correct fixture number and name
- have a copy of Smith submittal (rough-in) drawing with dimensions for fixture to be used.

NOTE: The rough-in dimensions listed on this drawing are based on current information available to Jay R. Smith by the fixture manufacturers. We recommend that you verify these dimensions with the fixture manufacturer. We will not accept responsibility for rough-in dimension changes by the fixture manufacturer.

PART	QTY	DESCRIPTION
1	2	Upright (w/welded base)
2	2	Sleeve Assembly
3	1	Alignment Bar
4	2	Locking Coupling
5	2	Escutcheon Fig. 0700 (-E)
6	2	Arm Assembly
6a	2	Rear Leveling Screw Assy
6b	2	Locking Device
6c	2	Front Leveling Screw

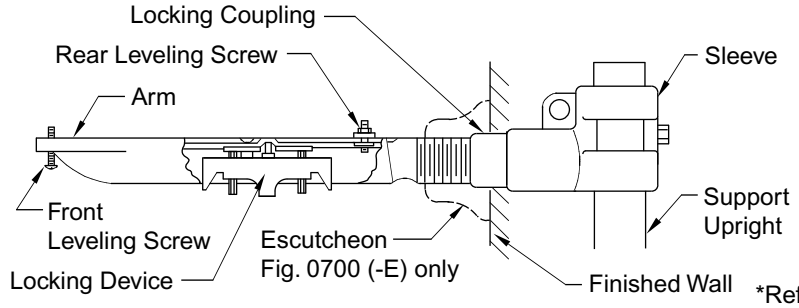
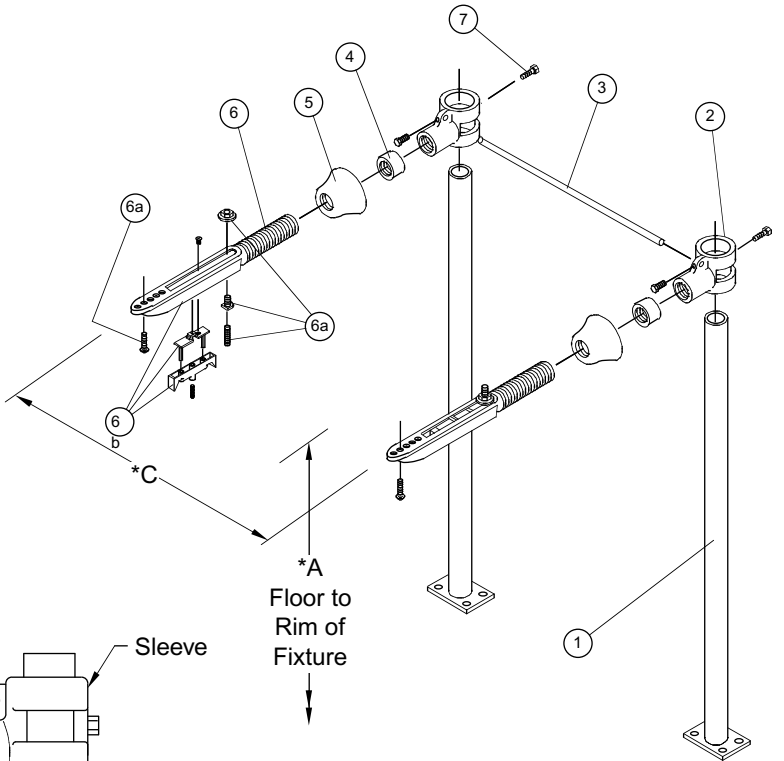

INSTALLATION INSTRUCTIONS FOR CONCEALED ARM CARRIERS

- Uprights (Part #1) must be spaced according to the "C" dimension (shown on the submittal drawing). Uprights should not be bolted rigidly to the floor at this time.
- Position sleeves (Part #2) by using the "B" dimension (shown on the submittal drawing). Secure to uprights with 5/16 (8)-18 hex head bolts (furnished) on the back of the sleeve.
- Slide alignment bar (Part #3) into the sleeves. Recheck the "C" dimension at the center of the uprights. Secure the alignment bar with 5/16 (8) hex head bolts (furnished). Uprights should now be bolted securely to the floor. Uprights must be plumb: if necessary, shim to compensate for uneven floors.
- Thread escutcheon (Part #5), Fig. 0700 (-E) only onto arm (Part #6). Thread locking coupling (Part #4) onto arm. Thread arms into sleeves (Part #2) to dimension "G" (shown on the submittal drawing). Lock arms in place by tightening locking coupling (Part #4). Recheck "C" dimension at the end of the arms.
- Rear leveling screw assemblies (Part #6a) must be set according to the "D" dimension (shown on the submittal drawing). Position the locking devices (Part #6b) to the "E" dimension (shown on the submittal drawing). Install the front leveling screws (Part #6b) to the "E" dimension (shown on the submittal drawing).
- Level lavatory with leveling screws as required and secure in place with locking device.

DRAWING NUMBER: S0700 INS
SIZE: A
SCALE: NONE
DATE: 8-8-85
APPROVED BY: KG
CHECKED BY: CR
DRAWN BY: VGD
FIGURE NUMBER: 0700, 0700 (-E)
INSTALLATION INSTRUCTIONS

WE CAN ASSUME NO RESPONSIBILITY FOR USE OF SUPERSEDED OR VOID DATA

DIMENSIONS ARE SUBJECT TO MANUFACTURERS TOLERANCE AND CHANGE WITHOUT NOTICE

REV.	DATE	DESCRIPTION	BY	CKD. BY	WEIGHT POUNDS	VOLUME CUBIC FEET	FIGURE NUMBER 0700, 0700 (-E) INSTALLATION INSTRUCTIONS

LAVATORY SUPPORTS WITH CONCEALED ARMS

FLOOR MOUNTED WITH "PRO-SET" UPRIGHTS

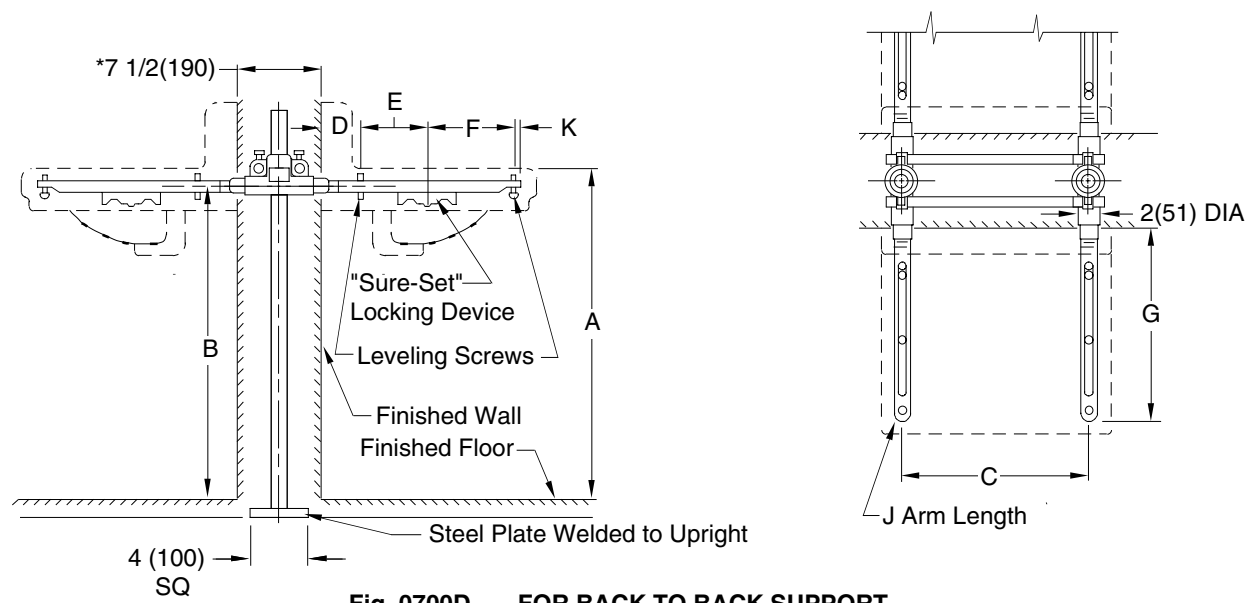
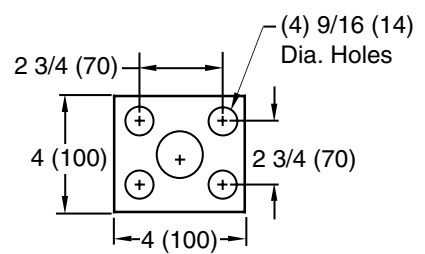

Fig. 0700D . . . FOR BACK TO BACK SUPPORT

NOTE: The rough-in dimensions listed on this drawing are based on current information available to Jay R. Smith by the fixture manufacturers. We recommend that you verify these dimensions with the fixture manufacturer. We will not accept responsibility for rough-in dimension changes by the fixture manufacturer.

NOTE: *This dimension can be increased when required (specify wall thickness).



BASE DETAIL

ROUGHING-IN TABLE

FIXTURE NAME				NUMBER			SIZE	
A	B	C	D	E	F	G	J	K

DRAWING NUMBER: S0700D (B)
 SIZE: A
 SCALE: NONE
 DATE: 1-22-73
 APPROVED BY: RP
 CHECKED BY: RP
 DRAWN BY: JH
 DIMENSIONS ARE SUBJECT TO MANUFACTURERS TOLERANCE AND CHANGE WITHOUT NOTICE

0700D

REV.	DATE	DESCRIPTION	BY	CKD. BY	WEIGHT POUNDS	VOLUME CUBIC FEET	FIGURE NUMBER 0700D
A	10-19-94	Submittal Update	EMB	BS			