



FIXTURE SUPPORTS

FOR LAVATORIES, SINKS, WATER COOLERS AND HOSPITAL FIXTURES

TECHNICAL DATA

Fixture supports have been designed to secure and support lavatories, sinks, electric water coolers, hospital service and scrub-up sinks, and many other types of off-the-floor fixtures. The supports for these fixtures are divided into two general categories: Floor Mounted Supports and Wall Mounted Supports.

"SURE-SET" CONCEALED ARMS

Specification and installation of "off-the-floor" lavatories, sinks and similar fixtures has greatly accelerated due to their many superior qualities. Smith engineers, recognizing this trend have greatly improved the existing methods of supporting these fixtures and among these improvements, sure-set concealed arms provide the most reliable method of supporting lavatories on concealed arms.



ENGINEERED FEATURES OF THE SMITH "SURE-SET" CONCEALED ARM

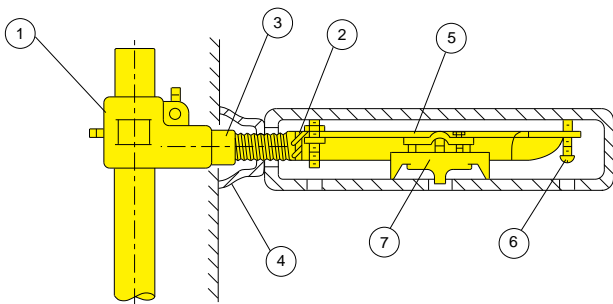

- ① **Adjustable Sleeve** - Adjusts vertically to meet specific rough-in heights and is threaded internally to receive concealed arm.
- ② **Threaded Concealed Arm** - Easily threaded into the adjustable sleeve for positive fixture support.
- ③ **Extended Lock Nut** - Accessible from the face of finished wall permanently locks the concealed arm in place.
- ④ **Threaded Escutcheon** - Chrome Plated and threaded to the concealed arm, stays permanently in place.
- ⑤ **Adjustment Slot** - Provides ease of adjusting locking device to suit the roughing-in dimensions of the fixture specified.
- ⑥ **Leveling Screws** - Are provided for proper leveling of fixture.
- ⑦ **"Sure-set" Locking Device** - Two serrated locking surfaces grip the bottom of the lavatory, permanently locking fixture to arm. Locking device boss protrudes through punching in underside of lavatory to prevent removal of the lavatory from the arm.
- ⑧ **Packaging** - Arms are separately packaged and fully assembled, ready for installation.

TYPICAL ARRANGEMENTS OF FLOOR AND WALL MOUNTED SUPPORTS

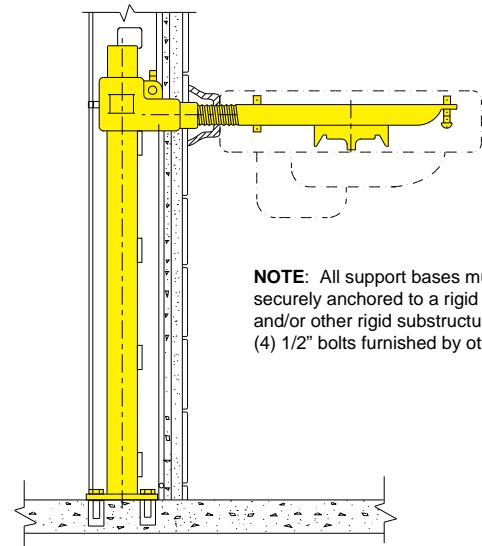

NOTE: All support bases must be securely anchored to a rigid floor and/or other rigid substructure with (4) 1/2" bolts furnished by others.

"PRO-SET" FLOOR MOUNTED UPRIGHT SUPPORT - "Pro-Set" is the trade name for the Smith system using uprights welded to base plates. This applies to round or rectangular uprights. The function of the support is to provide the means of mounting an off-the-floor fixture so that the vertical load bearing members are completely concealed inside the wall. This system has no external contact with the finished floor inside the room.

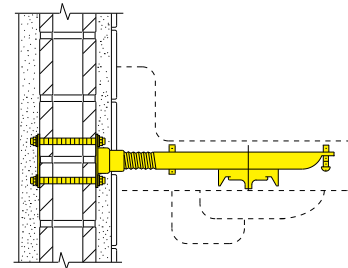

WALL MOUNTED SUPPORT - The function of this support is to provide for securing of the fixture to the wall in areas where a floor mounted support cannot be installed. The wall structure must be of sufficient strength to support the entire weight of the fixture.

NOTE: Single Plates for Battery Applications Available See Figs. 0722, 0722 (-E), 0728 and 0728 (-E).

REGULARLY FURNISHED: Floor or wall mounted supports with concealed or exposed arms, and/or with plate and studs as indicated by figure number selected. Exposed arm assemblies are acid resistant coated. Base supports for floor mounted type are welded to uprights. Escutcheons and exposed trim are chromium plated. Miscellaneous cast iron and steel parts are duco coated.

NOTE: SMITH provides Fixture Support Selection Guides which list the proper support for the fixture specified. Also furnished with each shipment of fixture supports are rough-in instructions of the support specified.

FURNISHED WHEN SPECIFIED - Exposed arm plate and studs with vandal proof trim. To specify, add Suffix -U to figure number of support desired.

NOTE: When ordering lavatories for use with concealed arms, it should be so stated to the fixture manufacturer so that the proper fixture will be furnished for use with a concealed arm support.

Although the concealed arm type of fixture support is the most popular today because of the various installation and esthetic features, there are two other basic types of fixture supports.



EXPOSED ARM SUPPORT

HANGER TYPE SUPPORT

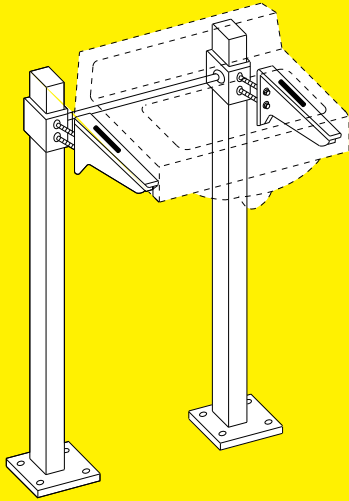

Vitreous China lavatory designed for use with acid resistant coated exposed arm support. Specify Fig. 0870 (-M31).

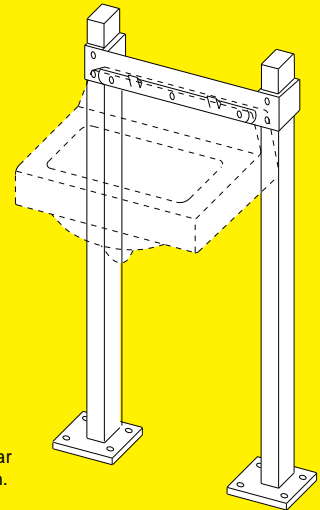

Enameled iron high back lavatory supported on a hanger type fixture support. Specify Fig. 0800 (-M31).

NOTE: It is recommended that Suffix -M31, 1 x 3 rectangular uprights (as shown) be used in non-load bearing wall construction.

SUPPORTS FOR HOSPITAL AND HANDICAPPED FIXTURES

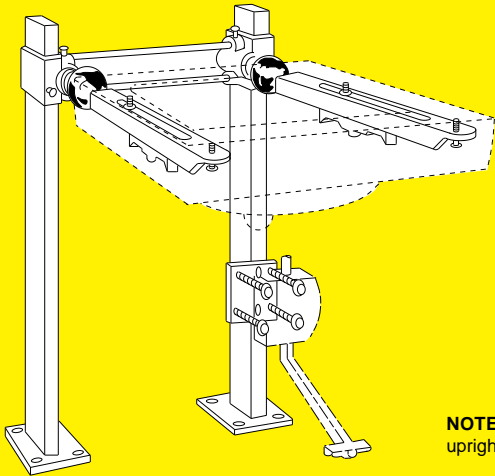

Surgeon's Lavatory - With pedal operated mixing valve for use in patient care areas. Specify Fig. 0700 (-E-KW-M31).

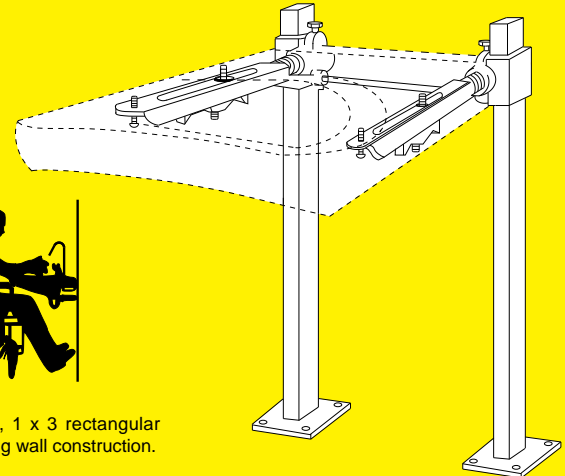

Wheelchair Lavatory - This lavatory has been expressly designed for wheelchair patient's needs. It provides adequate space beneath it for the wheelchair. Specify Fig. 0700 (-27-M31).

NOTE: It is recommended that Suffix -M31, 1 x 3 rectangular uprights (as shown) be used in non-load bearing wall construction.

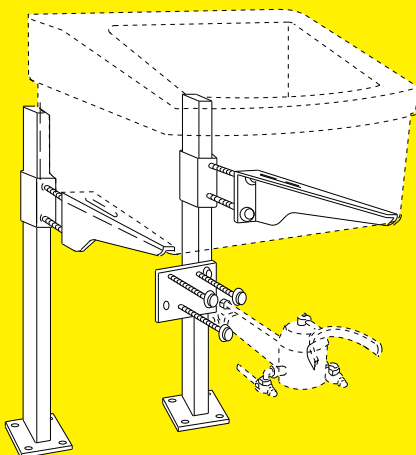

Surgeon's Scrub-up-Sink - For use in scrub rooms, emergency rooms and treatment areas, with knee-operated valve. Specify Fig. 0870 (-KW-M31).

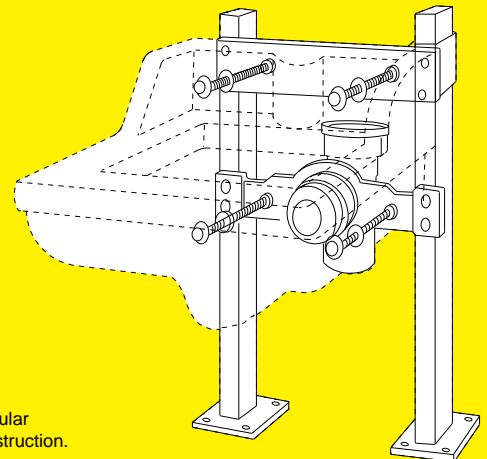

Clinic Service Sink - For use in utility rooms, emergency rooms and clean-up rooms. Specify Fig. 0915 (-M31). This support is supplied with a waste fitting and an adjustable coupling.

NOTE: It is recommended that Suffix -M31, 1 x 3 rectangular uprights (as shown) be used in non-load bearing wall construction.

Always specify fixture make, number and size. Specify knee-action or pedal valve name and number when required.

VARIATIONS AND INSTALLATION

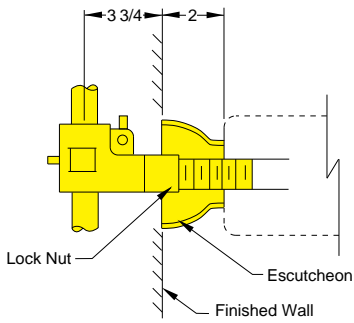

SUFFIX -E Threaded Escutcheon. When using lavatories of the flat slab type, the manufacturer requires a 2" dimension from the face of the wall to the rear of the lavatory. The 2" dimension prevents water from accumulating at the wall and causing deterioration. The escutcheon is chrome plated and is available on all concealed arm type supports. Add Suffix -E to figure number required.

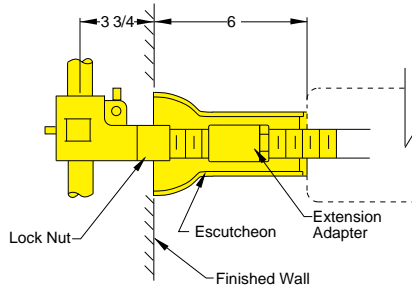

SUFFIX -E6 6" Long Threaded Escutcheon. When lavatories of the flat slab type are to be set away from the wall beyond the normal 2" setting, a 6" long escutcheon is provided with the same threaded arrangement as the regular 2" escutcheon. This escutcheon is chrome plated and is available on all concealed arm type supports. Add Suffix -E6 to figure number required.

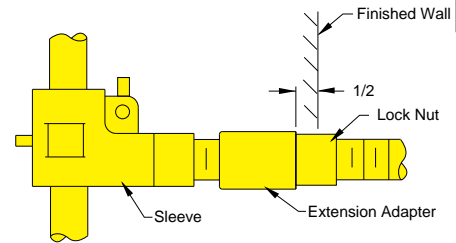

SUFFIX -M24 Extension Adaptor for Concealed Arm Support. When the standard (3 3/4") dimension from the face of the wall to the centerline of support upright, as shown in the illustration, is exceeded, use Suffix -M24 extension adaptor. The face of the extension adaptor should be set 1/2" in back of finished wall so the standard concealed arm and locking arrangement can be used for the lavatory regardless of the wall thickness. Add Suffix -M24 to Fig. No. required. **NOTE:** Always specify overall wall thickness and center line of support location.

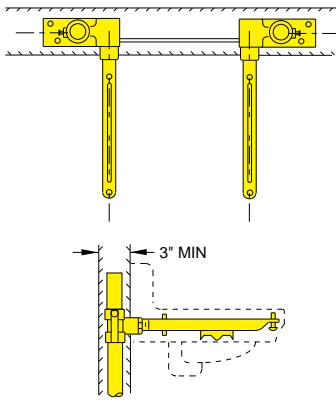

SUFFIX -Z Special Narrow Sleeve and Base for Concealed Arm Support. When a concealed arm lavatory support is to be installed in a narrow wall, a special narrow concealed arm sleeve and base are available for this type of installation. Add Suffix -Z to figure number required.

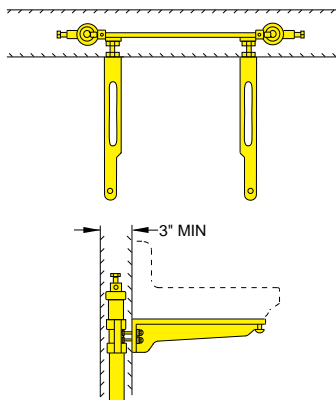

SUFFIX -Z Special Narrow Sleeve and Base for Exposed Arm Support. When an exposed arm lavatory or sink support is to be installed in a narrow wall, a special narrow sleeve and base are available for this type of installation. Add Suffix -Z to figure number required.

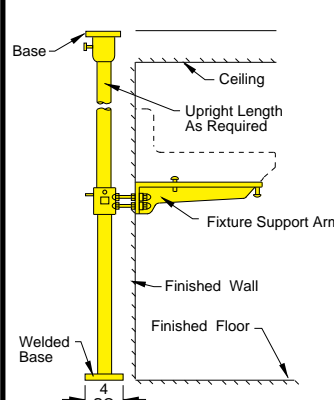

SUFFIX -M11 Floor-to-Ceiling Uprights When required, floor mounted fixture supports can be supplied with floor-to-ceiling uprights for securing to the floor and to the ceiling above. Add Suffix -M11 to figure number required.

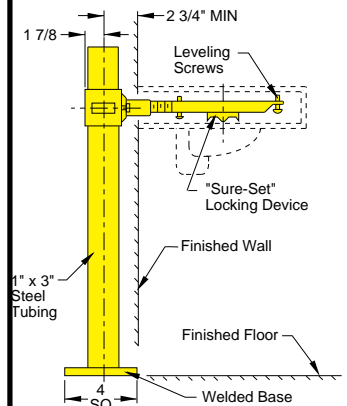

SUFFIX -M31 Rectangular Steel Uprights with Welded Bases. For use with metal stud and sheet rock wall construction. The rectangular shape upright offers greater structural strength and does not rely on the wall construction for support of the fixture. The rectangular upright keeps deflection to a minimum. For use with all floor mounted fixture supports. Add Suffix -M31 to figure number required.

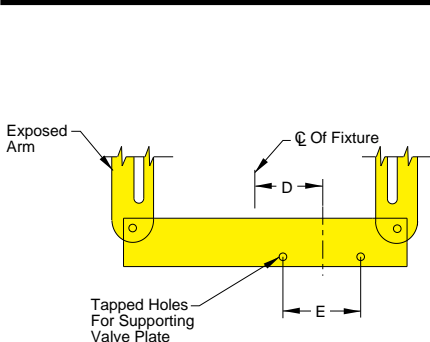

SUFFIX -KF Supporting Bar for Fixture Mounted Knee-Action Valve. Can be furnished on any exposed arm, wall or floor mounted sink support. Add Suffix -KF to figure number required.

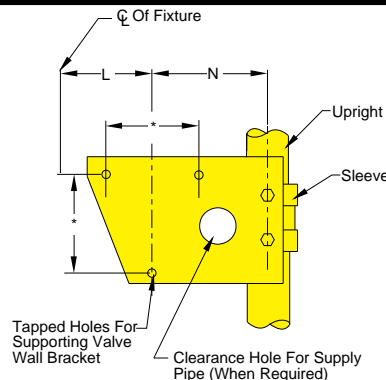

SUFFIX -KW Supporting Plate for Wall Mounted Knee-Action Valve. Can be furnished on any floor mounted lavatory or sink support. Add Suffix -KW to figure number required.

*Dimension based on valve used.

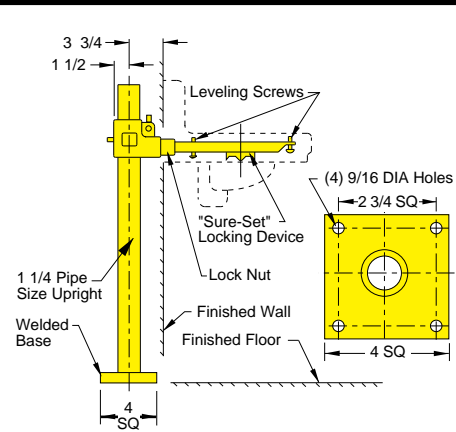

WELDED BASE Regularly Furnished. Round steel upright with welded base. Used with floor mounted fixture supports. The base should be securely anchored to the floor construction w/(4) 1/2" bolts. (By others)