

C

SMITH® JAY R. SMITH MFG. CO.®
 DIVISION OF SMITH INDUSTRIES, INC.
 POST OFFICE BOX 3237
 MONTGOMERY, ALABAMA 36109-0237 (USA)
 TEL: 334-277-8520 FAX: 334-272-7396 www.jrsmith.com



MEMBER OF:

LOCATION

INTERCEPTORS

BASKET STRAINER

FUNCTION: Installed at the suction side of pump equipment to intercept hair, lint, leaves, paper scraps and other debris which might damage the pump. Fig 8790 has a yoke type cover clamp for fast cover removal when basket has to be cleaned. Fig. 8795 has a bolted cover which is recommended where pressures are higher and protection against tampering is desired.

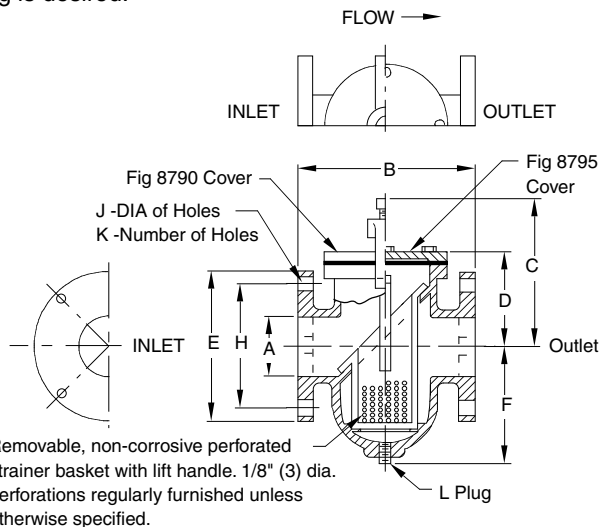
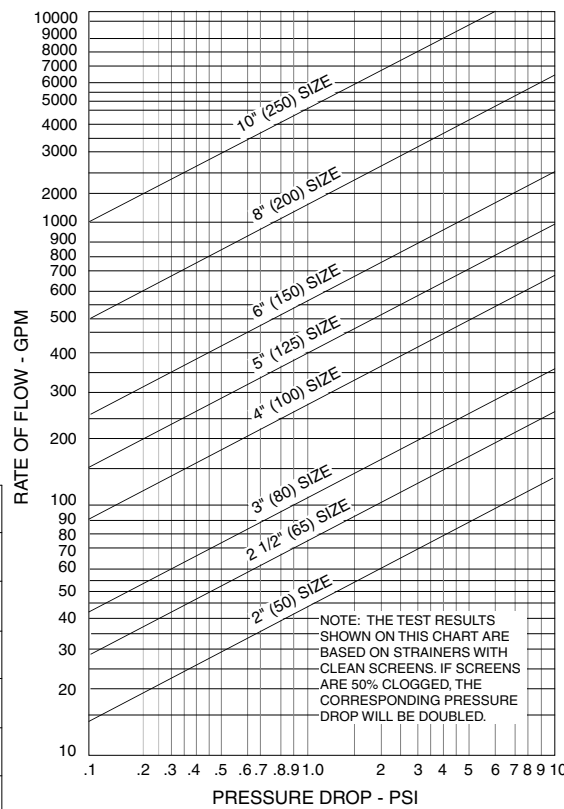

Fig. 8790. . . WITH YOKE TYPE COVER
 Fig. 8795. . . WITH BOLTED TYPE COVER

NOTE: Flange conforms to A.S.M.E. 125 lb. standards.

	A SIZE	B	C	D	E DIA	F	H DIA	J DIA	K	L	
<input type="checkbox"/>	8790-02	8795-02	8 3/4 (220)	7 3/4 (195)	4 1/2 (115)	6 (150)	5 1/2 (140)	4 3/4 (120)	3/4 (19)	4 (100)	3/4 (19)
<input type="checkbox"/>	8790-0250	8795-0250	8 3/4 (220)	7 3/4 (195)	4 3/4 (120)	7 (180)	5 1/2 (140)	5 1/2 (140)	3/4 (19)	4 (100)	3/4 (19)
<input type="checkbox"/>	8790-03	8795-03	8 3/4 (220)	7 1/4 (185)	4 1/2 (115)	7 1/2 (190)	6 (150)	6 (150)	3/4 (19)	4 (100)	3/4 (19)
<input type="checkbox"/>	8790-04	8795-04	11 (280)	7 1/2 (190)	5 (125)	9 (230)	7 3/4 (195)	7 1/2 (190)	3/4 (19)	8 (205)	3/4 (19)
<input type="checkbox"/>	8790-05	8795-05	11 (280)	8 1/4 (210)	5 1/4 (135)	10 (255)	8 1/2 (215)	8 1/2 (215)	7/8 (22)	8 (205)	1 1/4 (32)
<input type="checkbox"/>	8790-06	8795-06	15 1/4 (390)	10 3/4 (275)	6 1/2 (165)	11 (280)	12 3/4 (325)	9 1/2 (240)	7/8 (22)	8 (205)	1 1/4 (32)
<input type="checkbox"/>	8790-08	8795-08	17 (430)	11 (280)	6 1/2 (165)	13 1/2 (345)	15 1/4 (390)	11 3/4 (300)	7/8 (22)	8 (205)	1 1/4 (32)
<input type="checkbox"/>	8790-10	8795-10	21 1/2 (545)	13 (330)	8 (205)	16 (405)	17 1/2 (445)	14 1/4 (360)	1 (25)	12 (305)	1 1/4 (32)



PRESSURE DROP THROUGH FIG. 8790 AND FIG. 8795 AT VARIABLE FLOW RATES

NOTE: It is the responsibility of the installer to check all parts (internal and external) to verify they are in their proper operating order and location.

REGULARLY FURNISHED:
 Duco Coated Body and Cover.

NOTE: Dimensions shown in parentheses are in millimeters.

DRAWING NUMBER
S8790

SIZE
A

SCALE:
NONE

DATE:
12-11-84

APPROVED BY:
KG

CHECKED BY:
VGD

DRAWN BY:
CMB

8790, 8795

WE CAN ASSUME NO RESPONSIBILITY FOR USE OF SUPERSEDED OR VOID DATA

DIMENSIONS ARE SUBJECT TO MANUFACTURERS TOLERANCE AND CHANGE WITHOUT NOTICE

C B A	3-14-96 9-14-94 7-1-88	Added Millimeters Submittal Update Rev. Cover	EMB CMB CMB	BS BS
REV.	DATE	DESCRIPTION	BY	CKD. BY

WEIGHT POUNDS	VOLUME CUBIC FEET	FIGURE NUMBER 8790, 8795
------------------	----------------------	------------------------------------