



JAY R. SMITH MFG. CO.
 DIVISION OF SMITH INDUSTRIES, INC.
 POST OFFICE BOX 3237
 MONTGOMERY, ALABAMA 36109-0237 (USA)
 TEL: 334-277-8520 FAX: 334-272-7396 www.jrsmith.com



LOCATION

SOLIDS INTERCEPTOR

SUSPENDED TYPE

FUNCTION: Compact design makes this unit particularly adaptable for use directly under the fixture in place of the regular "P" trap. Unit will intercept all types of solids and precious metals. Interceptor is cleaned and inspected by removing bottom sediment strainer plate and dropping entire assembly.

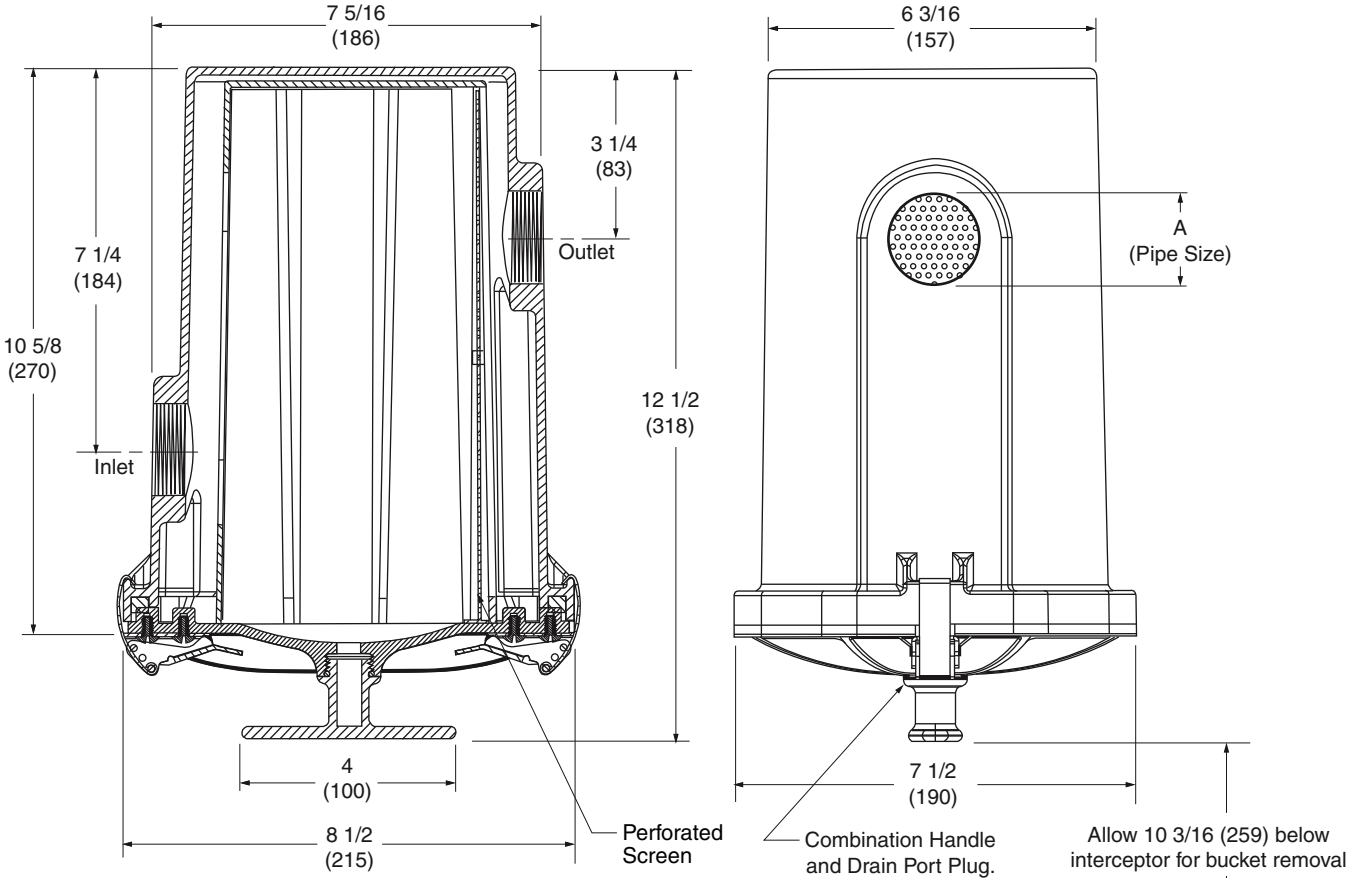

A (Pipe Size) = 0150 (38) or 02 (50)
 Fig. 8730T0150-ABS
 Fig. 8730T02-ABS

REGULARLY FURNISHED:
 All ABS White Body, Gasketed Cover with Stainless Steel Latches and Removeable Sediment Bucket with Removeable 3/32 (2) Diameter Perforated Screen.

NOTE: Dimensions shown in parentheses are in millimeters.

TYPICAL INSTALLATION

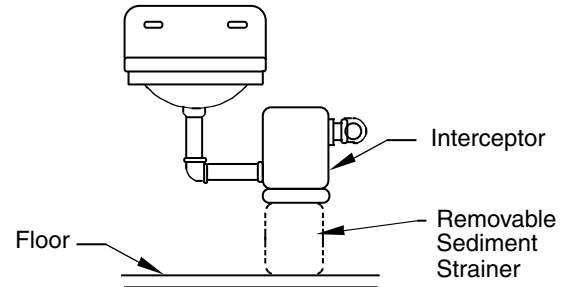

DRAWING NUMBER: s8730-ABS
 SIZE: A
 SCALE: NONE
 DATE: 7-11-03
 APPROVED BY: CEL
 CHECKED BY: CL
 DRAWN BY: RN

WE CAN ASSUME NO RESPONSIBILITY FOR USE OF SUPERSEDED OR VOID DATA
 DIMENSIONS ARE SUBJECT TO MANUFACTURERS TOLERANCE AND CHANGE WITHOUT NOTICE

REV.	DATE	DESCRIPTION	BY	CKD. BY

WEIGHT POUNDS	VOLUME CUBIC FEET

FIGURE NUMBER
8730-ABS

8730-ABS