



JAY R. SMITH MFG. CO.
 DIVISION OF SMITH INDUSTRIES, INC.
 POST OFFICE BOX 3237
 MONTGOMERY, ALABAMA 36109-0237 (USA)
 TEL: 334-277-8520 FAX: 334-272-7396 www.jrsmith.com



MEMBER OF:



LOCATION

8000-GT INTERCEPTOR SERIES ASSEMBLY INSTRUCTIONS

DRAWING NUMBER
PM 2721

SIZE
A

SCALE:
NONE

DATE:
2-8-84

APPROVED BY:
JMCD

CHECKED BY:
SUM

DRAWN BY:
PJ

PM 2721

WE CAN ASSUME NO RESPONSIBILITY FOR USE OF SUPERSEDED OR VOID DATA

DIMENSIONS ARE SUBJECT TO MANUFACTURERS TOLERANCE AND CHANGE WITHOUT NOTICE

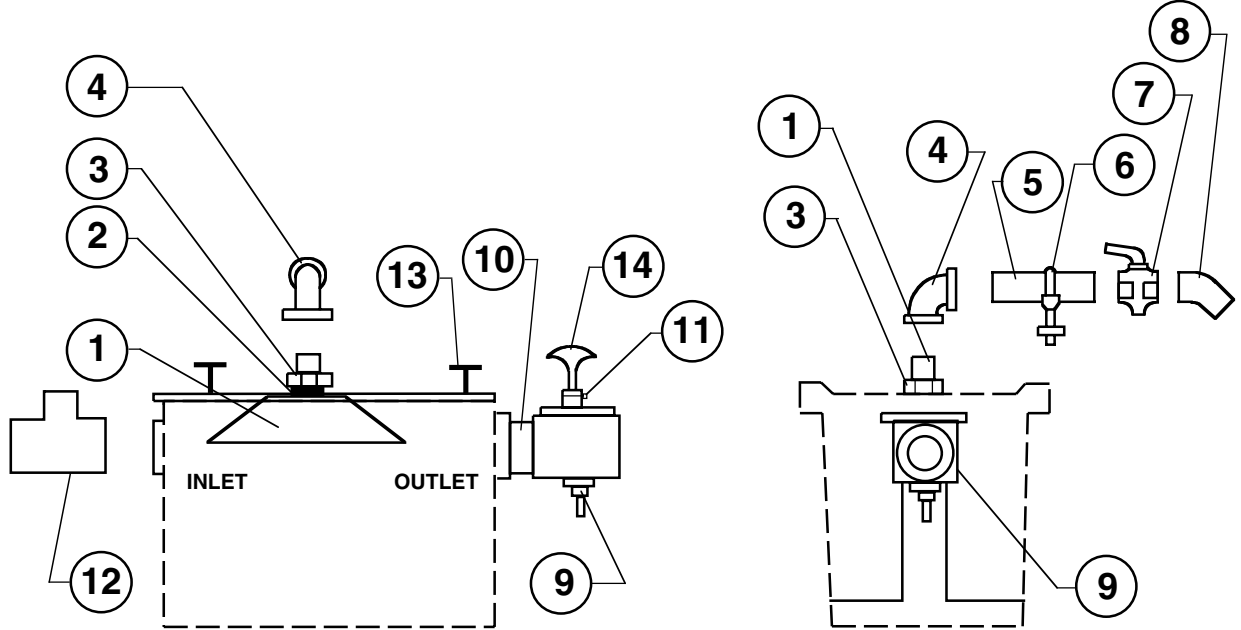

- ① Cone ② Cone Gasket ③ Nut ④ 90 Elbow ⑤ Nipple (Small Dia.)
- ⑥ Support Clamp ⑦ Draw Off Valve ⑧ 45 Elbow ⑨ Line Shut Off Valve
- ⑩ Nipple (Large Dia.) ⑪ Set Pin For Valve Handle ⑫ Flow Control Fitting
- ⑬ "T" Handle for Cover ⑭ Line Shut Off Valve Handle

- A. Remove parts from interior of interceptor.
- B. Remove plastic cap from center hole in cover. Place cone gasket (Item 2) between cone (Item 1) and bottom of cover. Insert cone (Item 1) from the bottom of cover thru center hole. Secure cone (Item 1) to cover with nut (Item 3).
- C. Return cover to correct position and tighten bolts.
- D. Assemble 90 elbow (Item 4), nipple (Item 5), draw-off valve (Item 7), and 45 elbow (Item 8) together and attach to the portion of the cone (Item 1) projecting above cover. Position this assembly to the desired side of interceptor. Locate support clamp (Item 6) around nipple (Item 5). Insert support clamp stud (Item 6) into threaded hole at edge of cover.
- E. Install line shut off valve (Item 9) and nipple (Item 10) at outlet side of interceptor. Install valve handle (Item 14) and secure with set pin (Item 11).
- F. Install flow control fitting (Item 12) at or near interceptor inlet.
- G. Install two "T" handles (Item 13) in threaded holes provided in cover at each end.

*Items 3,4,6 and 7 may be pre-assembled.

B	7-9-99	Updated Drawing	TBW	
A	1-18-95	Updated	CMB	
REV.	DATE	DESCRIPTION	BY	CKD. BY

WEIGHT POUNDS	VOLUME CUBIC FEET

FIGURE NUMBER
PM 2721