

NON-FREEZE GROUND HYDRANT

1 1/4 (32), 1 1/2 (38) or 2" (51) CONNECTIONS

FUNCTION: A Hydrant with a hinged covered box, for positive protection against freezing when buried outside or in unheated areas and the closing valve is located below the frost line. When hydrant is shut off, water is drained from the casing through the drain hole in the valve housing. The locking cover prevents unauthorized use.

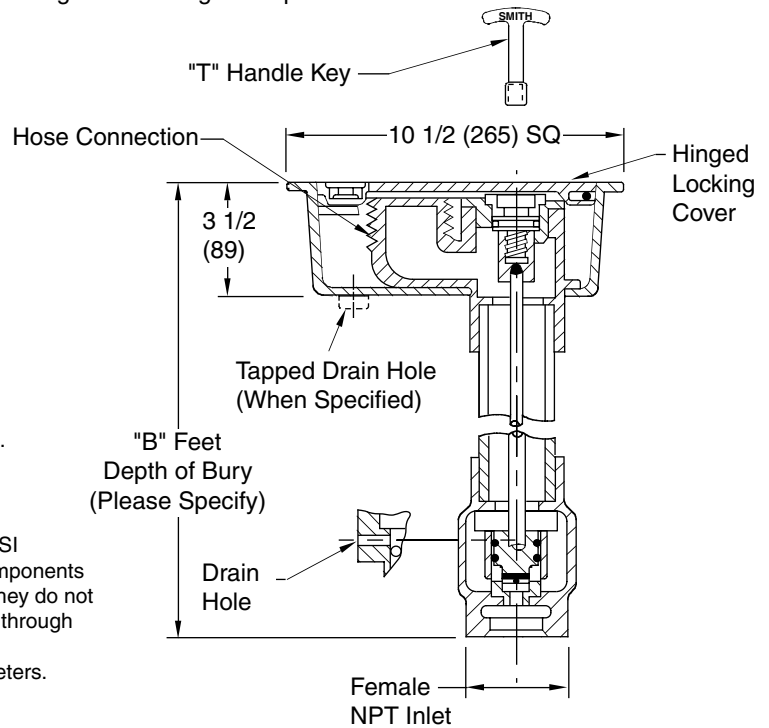
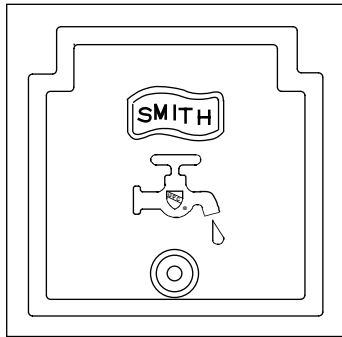

- NOTES:**
1. Recommended Box-out 9 1/2(240) x 9 1/2(240).
 2. All Jay R. Smith hydrants are manufactured with "NO-LEAD" brazing rings and USDA approved lubricants.
 3. The AB1953, California Lead Law, and NSF/ANSI Standard 61-2008 - Drinking Water System Components are not applicable to Jay R. Smith hydrants as they do not convey/dispense water for human consumption through drinking or cooking.
 4. Dimensions shown in parentheses are in millimeters.

B(Depth of Bury) = 02(610), 03(915), 04(1220), 05(1525), 06(1830), 07(2135) or 08(2438) Feet

	Fig. 5812 ... 1 1/4" (32)	}	INLET AND HOSE CONNECTIONS
	Fig. 5813 ... 1 1/2" (38)		
	Fig. 5814 ... 2" (51)		

REGULARLY FURNISHED:

Bronze Non-Freeze Ground Hydrant with "T" Handle Key and Cast Iron Hydrant Box Inlet and Hose Connection. Size Furnished as Indicated by Figure Number Selected.

VARIATIONS:

- | | |
|--|--|
| | 1/8" (3) NPT Drain Hole in Box -N |
| | 1/8" (3) NPT Drain Hole in Valve Housing -NV |
| | "Water" Cast on Cover -W |

OPTIONAL MATERIALS:

- | | |
|--|-------------------------|
| | Nickel Bronze Box -NB |
| | Polished Bronze Box -PB |
| | Rough Bronze Box -RB |

TECHNICAL DATA

Non-Freeze Ground Hydrants are supplied with a special valve housing which prevents freezing of hydrant during non-use periods. The valve housing must be installed below the frost line which prevails for the area of installation. The valve housing has a drain hole which drains the casing when the hydrant is shut off. In effect, there is no water in the casing during non-use periods. Since water from the drain hole is normally allowed to drain into the ground, the valve housing should be set in a bed of gravel. Water drained from the casing can then seep into the ground.

Some locations which require Non-Freeze Ground Hydrants cannot tolerate water draining from the drain hole. Examples are parking garages, plazas and roof decks used for recreational purposes. Often in these types of applications the valve housing will protrude into a finished area which is not subject to freezing temperatures. To eliminate the problem of water drainage in this type of installation, Smith can supply a tapped drain hole in the hydrant box and a tapped drain hole in the valve housing. Through these tapped drain holes, water accumulation in the box and the water from the valve housing drain hole can be piped to a suitable drain.

DRAWING NUMBER: S5812
 SIZE: A
 SCALE: NONE
 DATE: 12-8-88
 APPROVED BY: CR
 CHECKED BY: CR
 DRAWN BY: WAS
 FIGURE NUMBER: 5812, 5813, 5814

WE CAN ASSUME NO RESPONSIBILITY FOR USE OF SUPERSEDED OR VOID DATA

REV.	DATE	DESCRIPTION	BY	CKD. BY	WEIGHT POUNDS	VOLUME CUBIC FEET	FIGURE NUMBER
							5812,5813,5814

PARTS LIST WITH MAINTENANCE INSTRUCTIONS

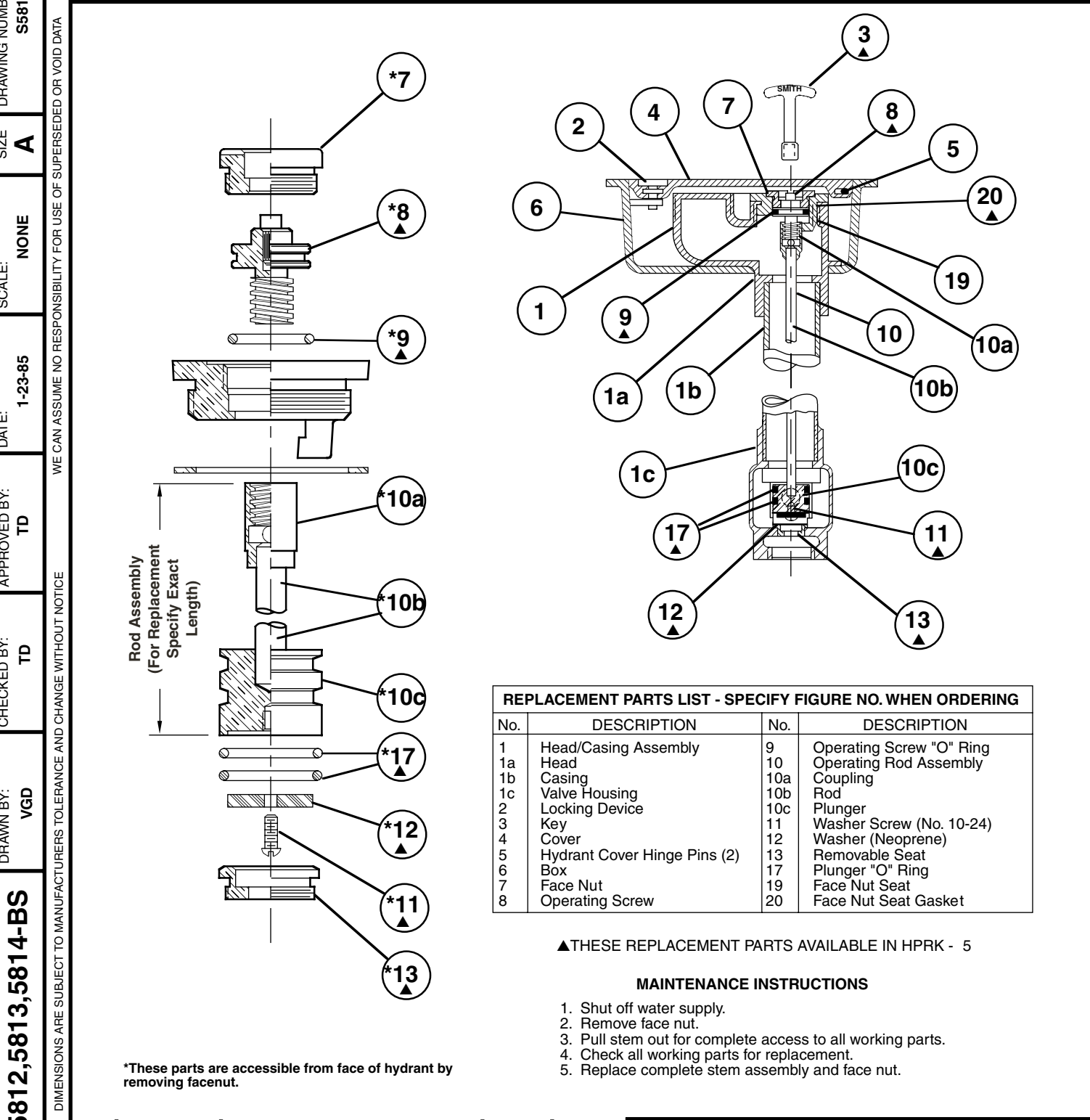

FIGURE NUMBER	5812,5813,5814-BS	DATE	9-22-93 6-30-93	DESCRIPTION	Added Note Submittal Update	BY	EMB EMB	CKD. BY	BS BS	WEIGHT POUNDS	VOLUME CUBIC FEET	FIGURE NUMBER
												5812,5813,5814

REPLACEMENT PARTS LIST - SPECIFY FIGURE NO. WHEN ORDERING			
No.	DESCRIPTION	No.	DESCRIPTION
1	Head/Casing Assembly	9	Operating Screw "O" Ring
1a	Head	10	Operating Rod Assembly
1b	Casing	10a	Coupling
1c	Valve Housing	10b	Rod
2	Locking Device	10c	Plunger
3	Key	11	Washer Screw (No. 10-24)
4	Cover	12	Washer (Neoprene)
5	Hydrant Cover Hinge Pins (2)	13	Removable Seat
6	Box	17	Plunger "O" Ring
7	Face Nut	19	Face Nut Seat
8	Operating Screw	20	Face Nut Seat Gasket

▲THESE REPLACEMENT PARTS AVAILABLE IN HPRK - 5

MAINTENANCE INSTRUCTIONS

1. Shut off water supply.
2. Remove face nut.
3. Pull stem out for complete access to all working parts.
4. Check all working parts for replacement.
5. Replace complete stem assembly and face nut.

*These parts are accessible from face of hydrant by removing facenut.

DRAWING NUMBER: S5812BS
 SIZE: A
 SCALE: NONE
 DATE: 1-23-85
 APPROVED BY: TD
 CHECKED BY: TD
 DRAWN BY: VGD

WE CAN ASSUME NO RESPONSIBILITY FOR USE OF SUPERSEDED OR VOID DATA
 DIMENSIONS ARE SUBJECT TO MANUFACTURERS TOLERANCE AND CHANGE WITHOUT NOTICE