

NON-FREEZE GROUND HYDRANT

3/4" (19) OR 1" (25) CONNECTIONS

FUNCTION: A Hydrant with a hinged covered box, for positive protection against freezing when buried outside or in unheated areas and the closing valve is located below the frost line. When hydrant is shut off, water is drained from the casing through the drain hole in the valve housing. The locking cover prevents unauthorized use.

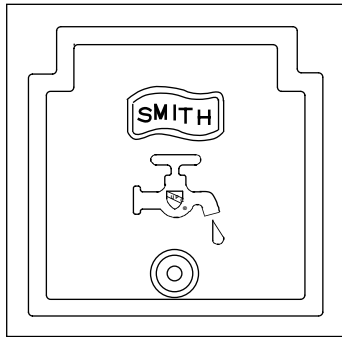

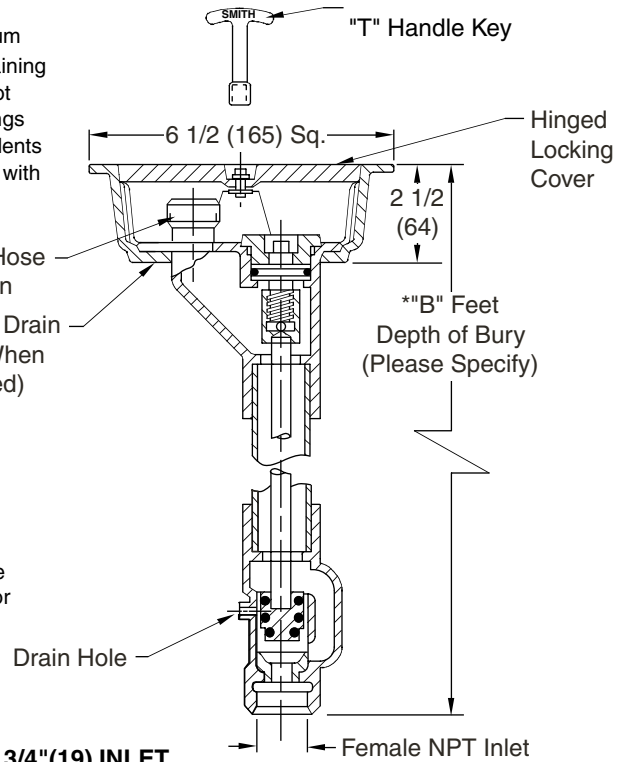

FRONT VIEW

NOTE: Addition of vacuum breaker will not allow draining of the casing. Smith is not responsible for any casings that burst or related incidents if the hydrant is supplied with a vacuum breaker.



- NOTES:**
1. Recommended Box-out 5 3/4 (145) x 5 3/4 (145).
 2. All Jay R. Smith hydrants are manufactured with "NO-LEAD" brazing rings and USDA approved lubricants.
 3. The AB1953, California Lead Law, and NSF/ANSI Standard 61-2008 - Drinking Water System Components are not applicable to Jay R. Smith hydrants as they do not convey/dispense water for human consumption through drinking or cooking.
 4. Dimensions shown in parentheses are in millimeters.

B(Depth of Bury) = 02(610), 03(915), 04(1220), 05(1525), 06(1830), 07(2135) or 08(2438) Feet
 *B = 9 1/2"(240) When Specified 5810-SAP
 *B = 9 1/2"(240) When Specified 5811-SAP

 **Fig. 5810... 3/4"(19) INLET**
 **Fig. 5811... 1"(25) INLET**

REGULARLY FURNISHED:
 Bronze Non-Freeze Ground Hydrant with "T" Handle Key, and Bronze Hydrant Box. Inlet Size Furnished as Indicated by Figure Number Selected.

- VARIATIONS:**
- 1"(25) Hose Connection Adaptor -HC1
 - Less Drain Hole -LD
 - 1/8"(3) NPT Drain Hole in Box -N
 - 1/8"(3) NPT Drain Hole in Valve Housing -NV
 - Mild Climate -SAP
 - "Water" Cast on Cover -W

- OPTIONAL MATERIALS:**
- Nickel Bronze Box -NB
 - Polished Bronze Box -PB

TECHNICAL DATA

Non-Freeze Ground Hydrants are supplied with a special valve housing which prevents freezing of hydrant during non-use periods. The valve housing must be installed below the frost line which prevails for the area of installation. The valve housing has a drain hole which drains the casing when the hydrant is shut off. In effect, there is no water in the casing during non-use periods. Since water from the drain hole is normally allowed to drain into the ground, the valve housing should be set in a bed of gravel. Water drained from the casing can then seep into the ground.

Some locations which require Non-Freeze Ground Hydrants cannot tolerate water draining from the drain hole. Examples are parking garages, plazas and roof decks used for recreational purposes. Often in these types of applications the valve housing will protrude into a finished area which is not subject to freezing temperatures. To eliminate the problem of water drainage in this type of installation, Smith can supply a tapped drain hole in the hydrant box and a tapped drain hole in the valve housing. Through these tapped drain holes, water accumulation in the box and the water from the valve housing drain hole can be piped to a suitable drain.

DRAWING NUMBER: S5810
 SIZE: A
 SCALE: NONE
 DATE: 12-8-88
 APPROVED BY:
 CHECKED BY:
 DRAWN BY: WAS
 FIGURE NUMBER: 5810,5811
 DIMENSIONS ARE SUBJECT TO MANUFACTURERS TOLERANCE AND CHANGE WITHOUT NOTICE
 WE CAN ASSUME NO RESPONSIBILITY FOR USE OF SUPERSEDED OR VOID DATA

N	6-13-11	Revised Note	TBW	CL	WEIGHT	VOLUME	FIGURE NUMBER
M	5-17-11	Added Note	TBW	CL	POUNDS	CUBIC FEET	5810,5811
L	10-7-09	Revised Notes	RN	CL			
K	5-3-06	Revised Optional Materials	TBW	CL			
REV.	DATE	DESCRIPTION	BY	CKD. BY			



JAY R. SMITH MFG. CO.
 MEMBER OF ACORN'S FAMILY OF COMPANIES
 POST OFFICE BOX 3237
 MONTGOMERY, ALABAMA 36109-0237 (USA)
 TEL: 334-277-8520 FAX: 334-272-7396 www.jrsmith.com



MEMBER OF:



LOCATION

PARTS LIST WITH MAINTENANCE INSTRUCTIONS

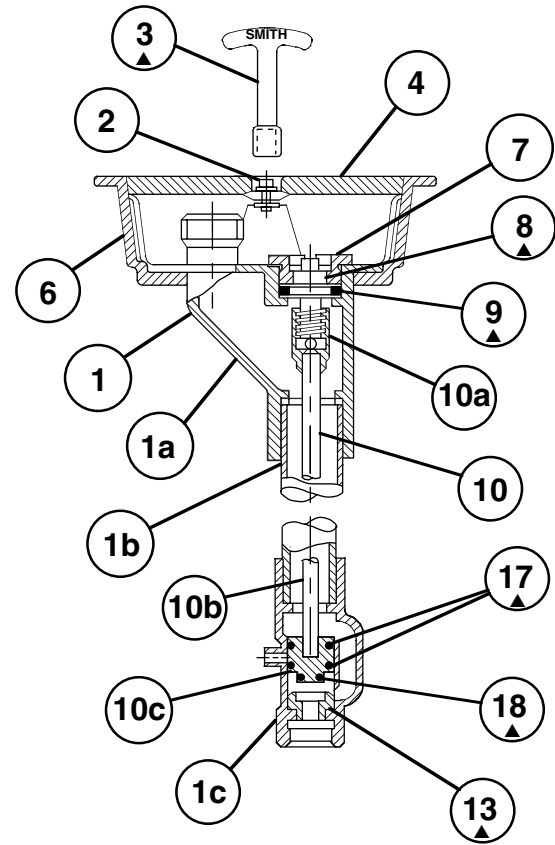
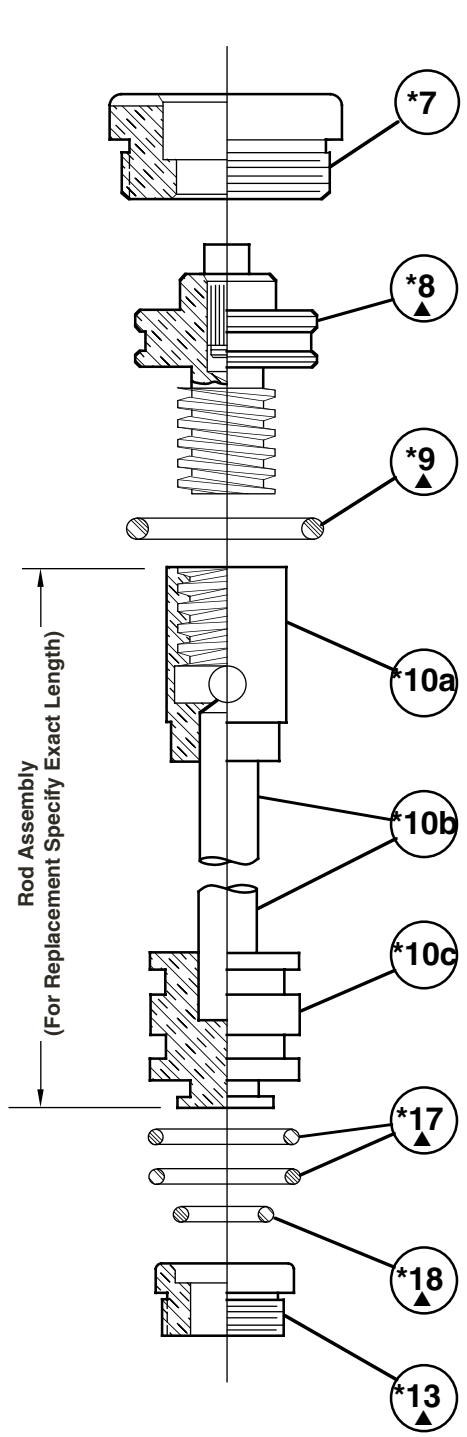

REPLACEMENT PARTS LIST - SPECIFY FIGURE NO. WHEN ORDERING			
No.	DESCRIPTION	No.	DESCRIPTION
1	Head/Casing Assembly	8	Operating Screw
1a	Head	9	Operating Screw "O" Ring
1b	Casing	10	Operating Rod Assembly
1c	Valve Housing	10a	Coupling
2	Locking Device	10b	Rod
3	Key	10c	Plunger
4	Cover	13	Removable Seat
5	Hydrant Cover Hinge Pins (2)	17	Plunger "O" Ring
6	Box	18	Plunger "O" Ring
7	Face Nut		

▲ THESE REPLACEMENT PARTS AVAILABLE IN HPRK-41

MAINTENANCE INSTRUCTIONS

1. Shut off water supply.
2. Remove face nut.
3. Pull stem out for complete access to all working parts.
4. Check all working parts for replacement.
5. Replace complete stem assembly and face nut.

*These parts are accessible from face of hydrant by removing face nut.

DRAWING NUMBER
S5810BS

SIZE
A

SCALE:
NONE

DATE:
1-23-85

APPROVED BY:
TD

CHECKED BY:
TD

DRAWN BY:
VGD

FIGURE NUMBER
5810, 5811BS

WE CAN ASSUME NO RESPONSIBILITY FOR USE OF SUPERSEDED OR VOID DATA

DIMENSIONS ARE SUBJECT TO MANUFACTURERS TOLERANCE AND CHANGE WITHOUT NOTICE

A	6-28-93	Submittal Update	EMB	CL
REV.	DATE	DESCRIPTION	BY	CKD. BY

WEIGHT POUNDS	VOLUME CUBIC FEET	FIGURE NUMBER 5810, 5811
------------------	----------------------	------------------------------------