



LOCATION

# EXPOSED 1/4 TURN NON-FREEZE "TWIN TEMP" WALL HYDRANT

**FUNCTION:** Provides positive non-freeze protection where water is required at the outside of the building. Ideal for use in food handling areas, dairies and other places where both hot and cold water are desired. 1/4 turn of the key allows full flow to be obtained.

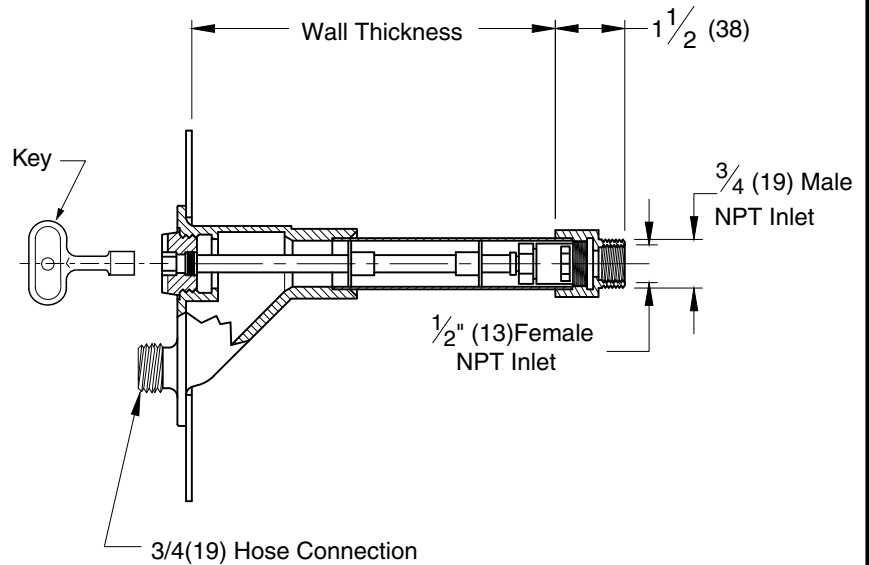
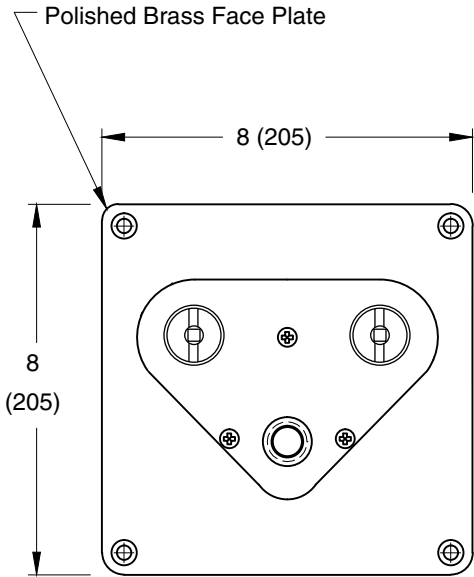

Fig. 5660QT ..... 1/2"(13) FEMALE & 3/4"(19) MALE INLET  
 Fig. 5661QT ..... 1"(25) MALE INLET

**REGULARLY FURNISHED:**

Bronze Quarter Turn Non-Freeze "Twin-Temp" Hydrant with 3/4"(19) Hose Connection, "T" Handle Key. Inlet Size Furnished as Indicated by Figure Number Selected.

**VARIATIONS:**

- Adjustable Wall Clamp -WC
- Wheel Handle -WH
- Vacuum Breaker Self Draining Type -H

**OPTIONAL MATERIALS:**

- Nickel Bronze Face -NB
- Chrome Plated Face -CP
- Rough Bronze Face -RB

**NOTES:**

1. Recommended wall opening 6"(150) x 6"(150).
2. When ordering, specify wall thickness in 2"(51) increments as follows: 6(150), 8(205), 10(255), 12(305), 14(355), 16(405), 18(455), 20(510), 22(560) or 24(610). When wall clamp -WC is desired, increase wall thickness dimension by 2"(51).
3. For hose to drain and provide non-freeze protection the hose MUST be removed from the hose connection.
4. All Jay R. Smith hydrants are manufactured with "NO-LEAD" brazing rings and USDA approved lubricants.
5. The AB1953, California Lead Law, and NSF/ANSI Standard 61-2008 - Drinking Water System Components are not applicable to Jay R. Smith hydrants as they do not convey/dispense water for human consumption through drinking or cooking.
6. Dimensions shown in parentheses are in millimeters.

DRAWING NUMBER  
5660QT, 5661QT

SIZE  
A

SCALE:  
NONE

DATE:  
7-8-11

APPROVED BY:  
CL

CHECKED BY:  
CL

DRAWN BY:  
TBW

**5660QT, 5661QT**

FIGURE NUMBER

WE CAN ASSUME NO RESPONSIBILITY FOR USE OF SUPERSEDED OR VOID DATA

REV.	DATE	DESCRIPTION	BY	CKD. BY	WEIGHT POUNDS	VOLUME CUBIC FEET	FIGURE NUMBER <b>5660QT, 5661QT</b>
------	------	-------------	----	---------	---------------	-------------------	--