



JAY R. SMITH MFG. CO.
 DIVISION OF SMITH INDUSTRIES, INC.
 POST OFFICE BOX 3237
 MONTGOMERY, ALABAMA 36109-0237 (USA)
 TEL: 334-277-8520 FAX: 334-272-7396 www.jrsmith.com



MEMBER OF:



LOCATION

FLOOR DRAINS

WIDE FLANGE BODIES WITH "SAFE-SET" BUCKET

FUNCTION: Used in areas where waste water contains solids or debris that must be prevented from entering drainage system. Wide flange allows adhesion of waterproof traffic deck covering, insuring watertight integrity. "Safe-Set" designs insures bucket replacement after cleaning. DX2565 is used for general light duty areas and the DX2566 is provided with large top to accommodate anticipated high flows.

Free Area
 9.25 SQ IN
 (60) SQ CM

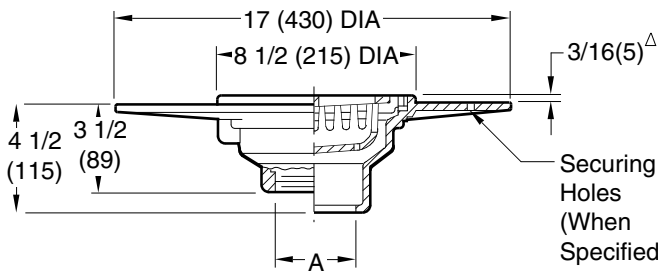

A (Pipe Size) = 02(50), 03(80) or 04(100)

Free Area
 25.25 SQ IN
 (163) SQ CM

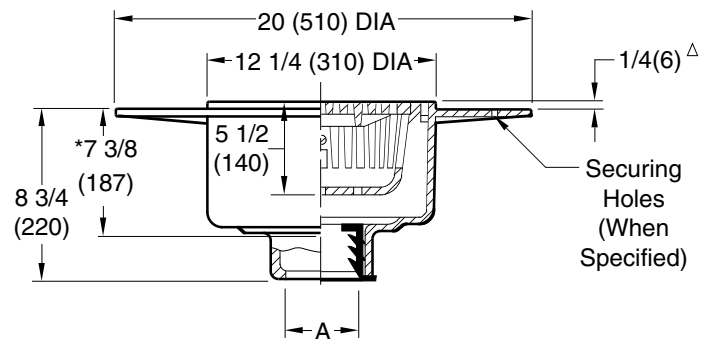

A (Pipe Size) = 02(50), 03(80), 04(100), 05(125) or 06(150)

Fig. DX2565C ... CAULK OUTLET
 Fig. DX2565T ... THREADED OUTLET

Fig. DX2566C ... CAULK OUTLET
 Fig. DX2566Y ... NO-HUB OUTLET

Δadd 3/16"(5) when bronze top is specified.
 *This dimension to internal stop of Speedi-Set gasket.

REGULARLY FURNISHED:

Duco Cast Iron 4"(100) Wide Flange Body with Bucket and Grate.

VARIATIONS:

- L Speedi-Set Service Weight
02(50), 03(80) & 04"(100) sizes only
(Fig. DX2566 Only)
- LXH Speedi-Set Extra Heavy
02(50), 03(80) & 04"(100) sizes only
(Fig. DX2566 Only)
- Membrane Clamp (Specify
Fig. DX2565R)
- NO-HUB Adaptor (Specify
Fig. 2646Y) (Fig. DX2565 only)
- Securing Holes -SH
- Vandal Proof Grate -U
- Y NO-HUB Outlet
- T Threaded Outlet
- Underdeck Clamp -UDC

OPTIONAL MATERIALS:

- Galvanized Cast Iron -G
- Nickel Bronze Top -NB
- Polished Bronze Top -PB

NOTE: Dimensions shown in parentheses are in millimeters.

DRAWING NUMBER
SDX2565

SIZE
A

SCALE:
NONE

DATE:
5-17-85

APPROVED BY:
TD

CHECKED BY:
TD

DRAWN BY:
PJ

FIGURE NUMBER
DX2565, DX2566

WE CAN ASSUME NO RESPONSIBILITY FOR USE OF SUPERSEDED OR VOID DATA

DIMENSIONS ARE SUBJECT TO MANUFACTURERS TOLERANCE AND CHANGE WITHOUT NOTICE

REV.	DATE	DESCRIPTION	BY	CKD. BY	WEIGHT POUNDS	VOLUME CUBIC FEET	FIGURE NUMBER
	04/22/04 4-9-97	Added UDC to Variations Added Millimeters	JJ EMB	CL BS			DX2565, DX2566