

C

SMITH® JAY R. SMITH MFG. CO.®
 DIVISION OF SMITH INDUSTRIES, INC.
 POST OFFICE BOX 3237
 MONTGOMERY, ALABAMA 36109-0237 (USA)
 TEL: 334-277-8520 FAX: 334-272-7396 www.jrsmith.com



LOCATION

PLANTING AREA DRAIN

FOR LARGE AREAS

FUNCTION: The perforated standpipe when surrounded by gravel fill, provides drainage of excess water from the planting or flower box. Top of standpipe is set at ground level and protected by dome cap. Excess surface water overflows into top of standpipe.

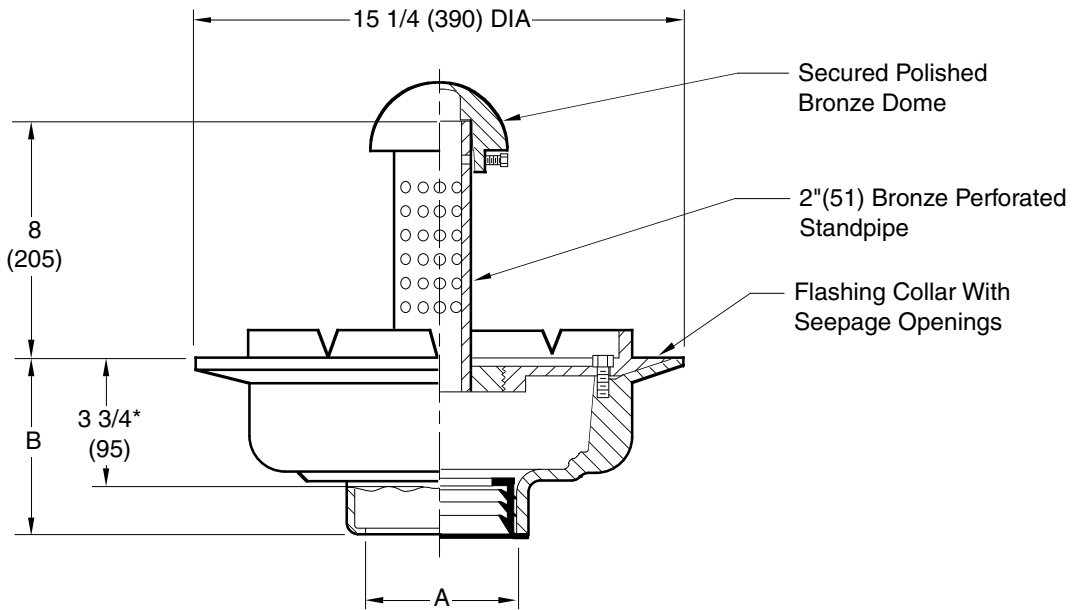

Fig. 2685C ... CAULK OUTLET
 Fig. 2685Y ... NO-HUB OUTLET

*This Dimension to Internal Stop of Speedi-Set Gasket.

A SIZE	02(50)	03(80)	04(100)
B	5(125) for Caulk, NO-HUB and Speedi-Set 3 3/4 (95) for Threaded		

REGULARLY FURNISHED:
 Duco Cast Iron Body and Flashing Collar with Bronze 8" High Standpipe and Polished Bronze Dome.

NOTE: Dimensions shown in parentheses are in millimeters.

VARIATIONS:

- L Speedi-Set Service Weight
- LXH Speedi-Set Extra Heavy
- Longer Standpipe (Specify)
- Solid Standpipe -SP
- Standpipe Covered with Stainless Steel Mesh -SSM
- T Threaded Outlet

OPTIONAL MATERIALS:

- Chrome Plated Dome and Standpipe -CPD
- Galvanized Cast Iron -G
- Nickel Bronze Dome Stainless Steel Standpipe -NBD
- Rough Bronze Dome -RBD

2685

DIMENSIONS ARE SUBJECT TO MANUFACTURERS TOLERANCE AND CHANGE WITHOUT NOTICE

DRAWING NUMBER S2685

SIZE A

SCALE: NONE

DATE: 5-17-85

APPROVED BY: TD

CHECKED BY: TD

DRAWN BY: PJ

FIGURE NUMBER

REV.	DATE	DESCRIPTION	BY	CKD. BY
C	5-22-95	Revised and added millimeters	CMB	BS
B	7-5-94	Revised	CMB	BS
A	11-17-93	Submittal Update	EMB	BS

WEIGHT POUNDS	VOLUME CUBIC FEET

FIGURE NUMBER
2685