

C

**SMITH® JAY R. SMITH MFG. CO.®**  
 DIVISION OF SMITH INDUSTRIES, INC.  
 POST OFFICE BOX 3237  
 MONTGOMERY, ALABAMA 36109-0237 (USA)  
 TEL: 334-277-8520 FAX: 334-272-7396 www.jrsmith.com



LOCATION

DRAWING NUMBER  
S2670

SIZE  
A

SCALE:  
NONE

DATE:  
5-17-85

APPROVED BY:  
TD

CHECKED BY:  
TD

DRAWN BY:  
PJ

2670,2671,2673,2674

WE CAN ASSUME NO RESPONSIBILITY FOR USE OF SUPERSEDED OR VOID DATA

DIMENSIONS ARE SUBJECT TO MANUFACTURERS TOLERANCE AND CHANGE WITHOUT NOTICE

# PLANTING AREA DRAINS

## FOR SMALL AREAS

**FUNCTION:** Provides for the drainage of any excess moisture which builds up in planting or flower boxes. Heavy stainless steel mesh screen over the dome prevents soil or stones from entering the drain line.

Free Area  
25 SQ IN  
(161) SQ CM

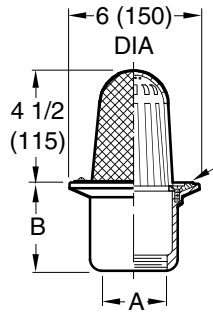

**THREADED OUTLET**  
Caulk When Specified

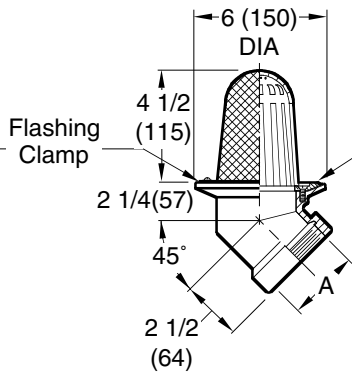

**Fig. 2673T**  
**THREADED OUTLET**

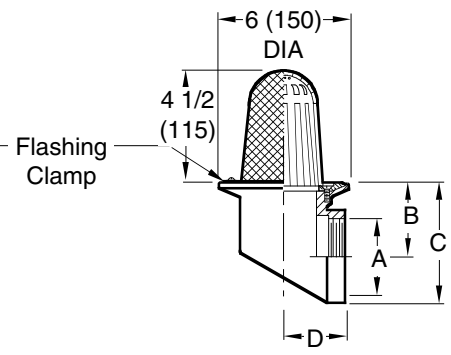

**Fig. 2674T**  
**THREADED OUTLET**

Fig. No.	A SIZE	B
2670T	02(50), 03(80) thread	2(51)
2670C	02(50) caulk	
2671T	02(50), 03(80), 04(100) thread	4(100)
2671C	02(50) caulk	

A SIZE	02(50)	03(80)	04(100)
B	2 1/2(64)	3(76)	3 1/2(89)
C	4(100)	5 1/4(135)	4(100)
D	2 1/2(64)	3(76)	6 1/4(160)

**NOTE:** Dimensions shown in parentheses are in millimeters.

**REGULARLY FURNISHED:**  
 Duco Cast Iron Body, Bronze Flashing Clamp, Secured Bronze Dome with Stainless Steel Mesh Screen.

**VARIATIONS:**  
 NO-HUB Adaptor (Specify Fig. 2646Y)  
 Vandal Proof Dome -U

**OPTIONAL MATERIALS:**  
 Bronze Body -BB  
 Galvanized Cast Iron -G  
 Nickel Bronze Dome -NB

REV.	DATE	DESCRIPTION	BY	CKD. BY
C	8-2-07	Added Dim. to Submittal Added Millimeters Submittal Update	RN	CL
B	4-14-97		EMB	BS
A	11-17-93		EMB	BS

WEIGHT POUNDS  
VOLUME CUBIC FEET

**FIGURE NUMBER**  
**2670, 2671,**  
**2673, 2674**