

HEAVY DUTY INDUSTRIAL DRAIN

WHITFORD STYLE DRAIN

FUNCTION: Used in packing houses and industrial plants where large quantities of water must be drained and heavy traffic is anticipated. Debris and solids are retained in a suspended bucket which is readily and easily emptied.

Grate Free Area
 38.5 SQ IN
 (248) SQ CM

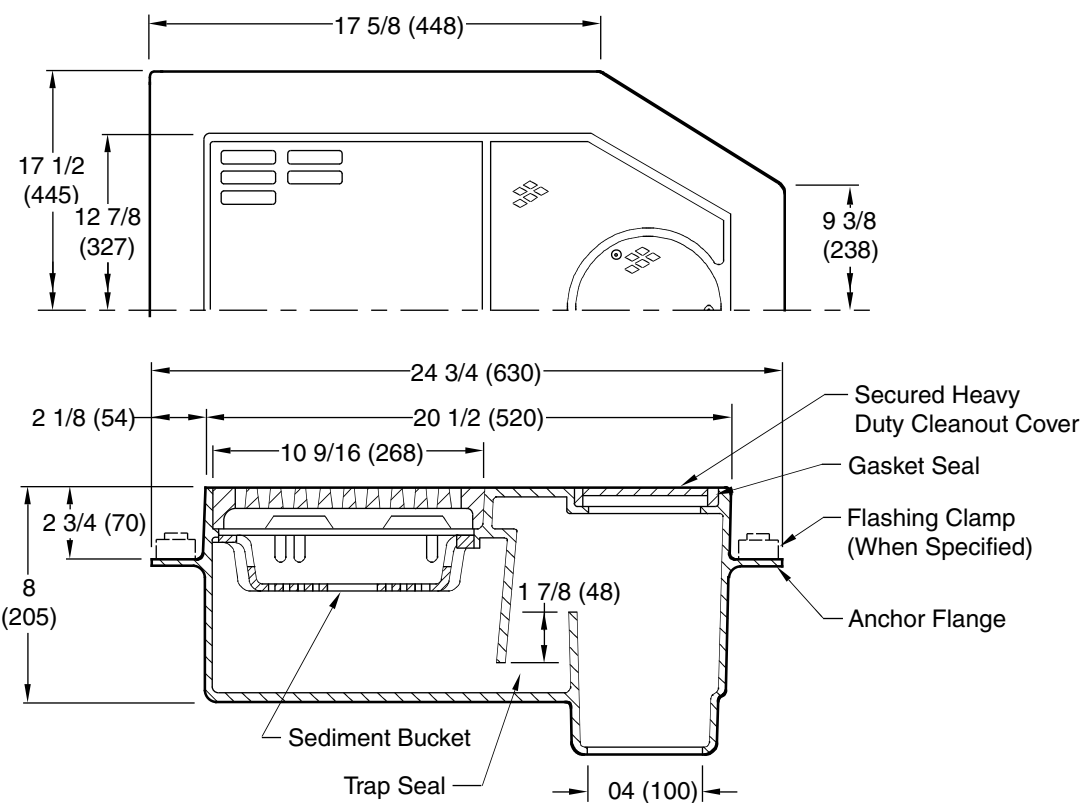

- Fig. 2484C . . . CAULK OUTLET
- Fig. 2484T . . . THREADED OUTLET
- Fig. 2484Y . . . NO-HUB OUTLET

REGULARLY FURNISHED:
 Fabricated Steel Body with Acid Resistant Coating Inside and Outside with Heavy Duty Cast Iron Tractor Grate, Aluminum Sediment Bucket, and Secured Heavy Duty Cleanout Cover.

- VARIATIONS:**
- Cast Iron Bucket -CIB
 - Flashing Clamp -C
 - Seepage Holes -W
 - Vandal Proof Top -U

- OPTIONAL MATERIALS:**
- Ductile Iron Grate -M
 - Galvanized -G

- OUTLET VARIATIONS:**
- 03(75) Caulk 4(100) x 3(75) Reducer
 - 02(50) NO-HUB
 - 03(75) NO-HUB
 - 04(100) NO-HUB
 - 02(50) Threaded 4(100) x 2(50) Bushing
 - 03(75) Threaded 4(100) x 3(75) Bushing
 - 04(100) Threaded

NOTE: Dimensions shown in parentheses are in millimeters.

DRAWING NUMBER: S2484
 SIZE: A
 SCALE: NONE
 DATE: 2-8-88
 APPROVED BY: McD
 CHECKED BY: SB
 DRAWN BY: CMB
 FIGURE NUMBER: 2484

WE CAN ASSUME NO RESPONSIBILITY FOR USE OF SUPERSEDED OR VOID DATA

G	7-29-02	Rev. Dwg., Regularly Fur. & Fig.	RN	CL	WEIGHT POUNDS	VOLUME CUBIC FEET	FIGURE NUMBER 2484
F	6-8-99	Rev. Variations & Millimeters	TBW	BS			
D	6-15-95 10-15-93	Added Millimeters Submittal Updated	EMB EMB	BS BS			
REV.	DATE	DESCRIPTION	BY	CKD. BY			