

E

SMITH® JAY R. SMITH MFG. CO.
 DIVISION OF SMITH INDUSTRIES, INC.
 POST OFFICE BOX 3237
 MONTGOMERY, ALABAMA 36109-0237 (USA)
 TEL: 334-277-8520 FAX: 334-272-7396 www.jrsmith.com



LOCATION

DRAWING NUMBER
S2420

SIZE
A

SCALE:
NONE

DATE:
5-17-85

APPROVED BY:
SB

CHECKED BY:
McD

DRAWN BY:
EMB

2420, 2425

WE CAN ASSUME NO RESPONSIBILITY FOR USE OF SUPERSEDED OR VOID DATA

TRAFFIC FLOOR DRAINS

SQUARE TOP - FREE STANDING SEDIMENT BUCKET

FUNCTION: Used in boiler rooms and industrial plants where waste water contains debris or salvageable materials which must be intercepted. Large hinged grate permits easy access for bucket removal.

Free Area
27 SQ IN
(174) SQ CM

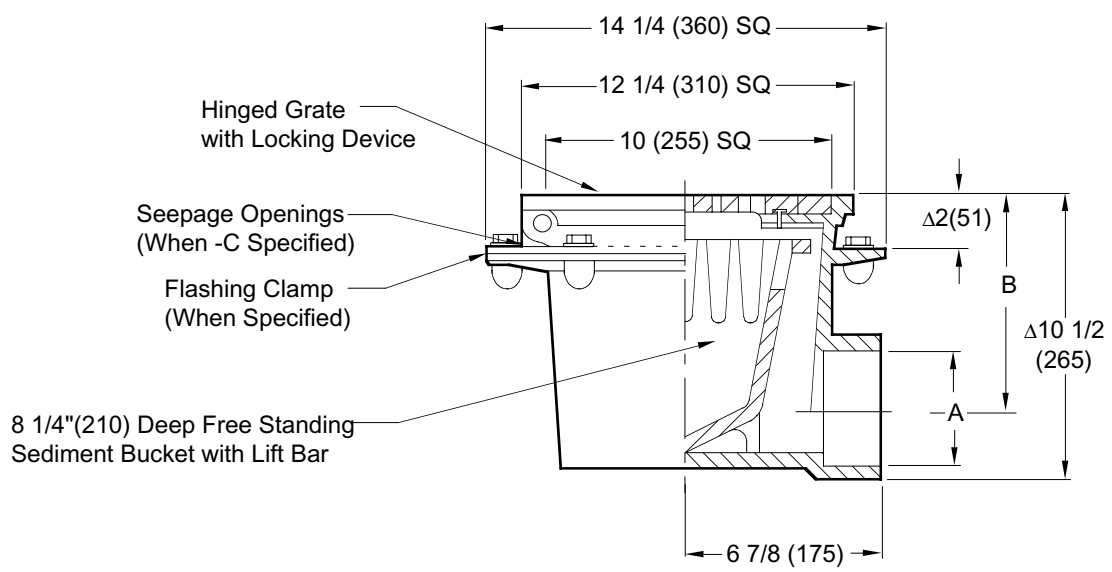

Fig. 2420C LESS FLANGE
 Fig. 2425C WITH FLANGE

A SIZE	03(80)	04(100)	05(125)	06(150)
B	6 1/4(160)	5 3/4(145)	5 1/4(135)	4 3/4(120)

CAULK OUTLET ONLY

NOTE: Dimensions shown in parentheses are in millimeters.

Δ add 3/16"(5) when bronze top is specified

REGULARLY FURNISHED:
 Duco Cast Iron Body with Hinged Grate, Locking Device and Sediment Bucket.

- VARIATIONS:**
- Deflector Grate -DG
 - Flashing Clamp -C (Fig. 2425 only)
 - Loose Set Grate -LSG
 - Vandal Proof Grate -U

- OPTIONAL MATERIALS:**
- Ductile Iron Grate -M
 - Galvanized Cast Iron -G
 - Nickel Bronze Top -NB
 - Polished Bronze Top -PB

REV.	DATE	DESCRIPTION	BY	CKD. BY	WEIGHT POUNDS	VOLUME CUBIC FEET	FIGURE NUMBER 2420, 2425
E	4-9-97	Added Millimeters	EMB	BS			
D	7-5-94	Revised	CMB	BS			
C	10-5-93	Chg Dim & Submittal Update	EMB	BS			
B	3/92	Chg Callout	EMB	BW			