

G
 DRAWING NUMBER
 S2142, 2147
 SIZE
 A
 SCALE:
 NONE
 DATE:
 5-17-85
 APPROVED BY:
 TD
 CHECKED BY:
 TD
 DRAWN BY:
 BS
 2142, 2147
 DIMENSIONS ARE SUBJECT TO MANUFACTURERS TOLERANCE AND CHANGE WITHOUT NOTICE

FLOOR DRAINS

WITH HEAVY DUTY TRACTOR GRATE

12" (305) ROUND TOP SOLID FREE STANDING SEDIMENT BUCKET

FUNCTION: Used in heavy trucking or traffic areas where waste water contains sand, sediment and other debris. Drain has solid free standing bucket to intercept this type of debris.

Free Area
 29 SQ IN
 (187) SQ CM

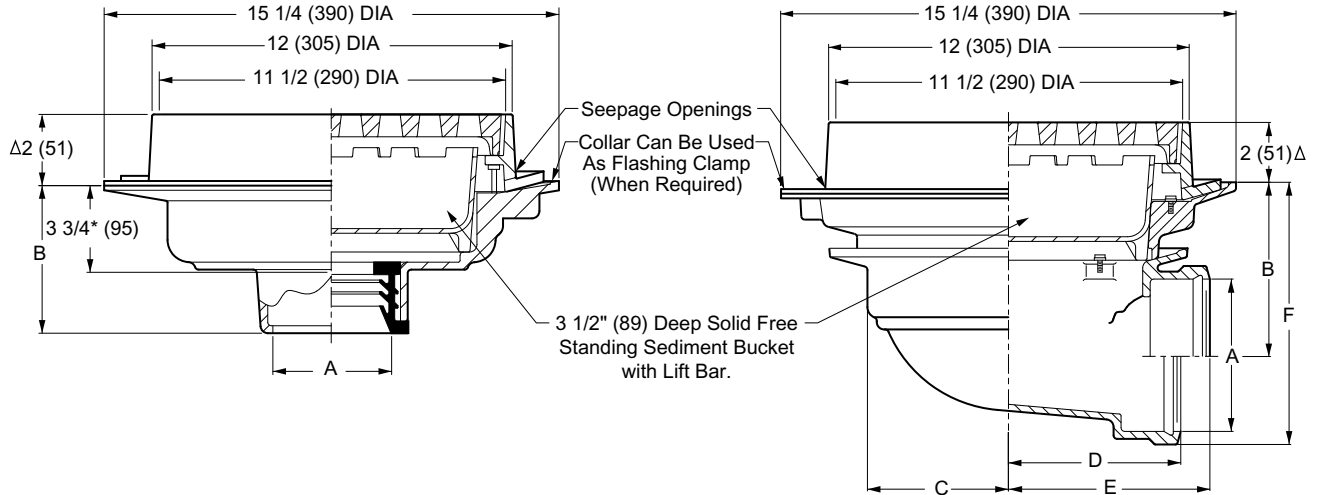

Fig. 2142C.....CAULK OUTLET
 Fig. 2142Y.....NO-HUB OUTLET

Fig. 2147C.....CAULK OUTLET
 Fig. 2147T.....THREADED OUTLET

A Size	B	
	Caulk, NO-HUB & Speedi-Set	Threaded
02(50), 03(75), 04(100), 05(125) & 06(150)	5 (125)	3 3/4 (95)

A SIZE	02(50)	03(75)	04(100)	05(125)	06(150)
B	6 7/8(175)	6 3/8(162)	5 7/8(149)	5(125)	4 1/2(115)
C	4 3/4(120)	4 3/4(120)	4 3/4(120)	6 1/4(160)	6 1/4(160)
D	6(150)	6(150)	6(150)	6 5/8(168)	6 7/8(175)
E	7 1/4(185)	7 1/2(190)	7 3/4(195)	7 3/4(195)	7 3/4(195)
F	8 5/8(219)	8 3/4(220)	8 3/4(220)	8 1/2(215)	8 1/2(215)

REGULARLY FURNISHED:
 Ducto Cast Iron Body and Flashing Collar with Cast Iron Tractor Grate and Solid Free Standing Sediment Bucket.

- VARIATIONS:**
- Flat Bottom Strainer -FBS
 - L Speedi-Set Service Weight 02(50), 03(75) & 04"(100) sizes only. (Fig. 2142 only)
 - LXH Speedi-Set Extra Heavy 02(50), 03(75) & 04"(100) sizes only. (Fig. 2142 only)
 - NO-HUB Adaptor (Specify Fig. 2646Y) (Fig. 2140 & 2147 only)
 - Seepage Holes in Bucket -FP (Frost Proof)
 - Square Top -S
 - Trap Primer Connection -P050 1/2" (13) & -P075 3/4" (19) (Fig. 2142 only)
 - Vandal Proof Grate -U
 - T Threaded Outlet

- OPTIONAL MATERIALS:**
- Ductile Iron Grate -M
 - Galvanized Cast Iron -G
 - Nickel Bronze Top -NB
 - Polished Bronze Top -PB

Δ Add 1/8" (3) when bronze top is specified.
 *This dimension to internal stop of Speedi-Set gasket.

NOTE: 02(50, 03(75), & 04"(100) sizes require a transition collar (as shown in above illustration) which fits between the body & collar. 05(12) & 06"(150) sizes do not require transition collar.

NOTE: Dimensions shown in parentheses are in millimeters.

REV.	DATE	DESCRIPTION	BY	CKD.	WEIGHT POUNDS	VOLUME CUBIC FEET	FIGURE NUMBER
	01/30/04 1-18-99 2-6-96	Revised Bucket Note Submittal redraw Illustrator Added Millimeters	JJ CMD EMB	JM BS BS			2142, 2147