

FLOOR DRAIN WITH INTEGRAL TRAP

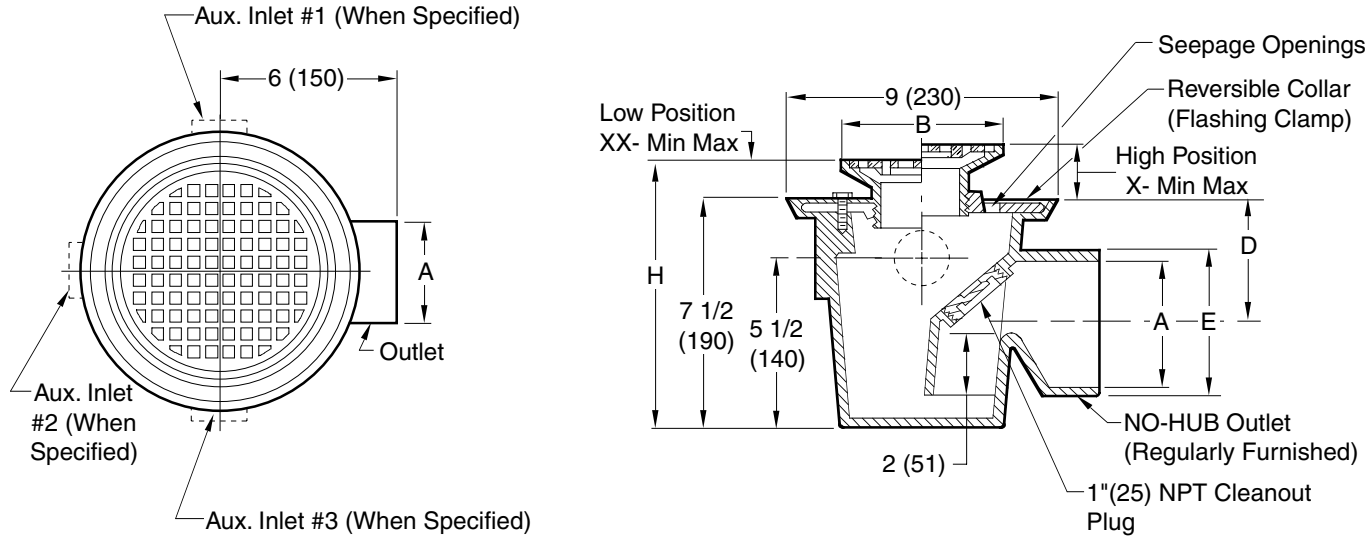

AVAILABLE STRAINERS

Strainer Size	*Collar In High Position		*Collar In Low Position		Free Area Sq. In. (Sq. Cm.)		H MIN
	X		XX		Round	Square	
B	Min.	Max.	Min.	Max.			
05 (125)	1 1/4 (32)	2 1/4 (57)	3/4 (19)	1 5/8 (41)	7 (45.16)	6.5 (41.94)	8 1/4 (210)
06 (150)	1 1/4 (32)	2 1/4 (57)	3/4 (19)	1 5/8 (41)	9 (58.07)	12.5 (80.65)	
07 (180)	1 1/4 (32)	2 1/4 (57)	7/8 (22)	1 7/8 (48)	14 (90.33)	11 (70.97)	8 3/8 (213)
08 (205)	1 1/2 (38)	2 1/2 (63)	1 (25)	1 7/8 (48)	17 (109.68)	14 (90.33)	
• 09 (230)	1 1/2 (38)	2 3/8 (60)	1 (25)	1 7/8 (48)	18 (116.14)	16 (103.23)	8 1/2 (215)
• 10 (255)	1 1/2 (38)	2 3/8 (60)	1 (25)	1 7/8 (48)	23 (148.40)	16 (103.23)	

A PIPE SIZE	D	E
02 (50)	3 3/16 (80)	2 5/16 (58.67)
03 (76)	3 11/16 (93)	3 3/8 (85.95)
04 (100)	4 3/16 (106)	4 3/8 (111)

• Add 3/8" (10) To All Min./Max. Dimensions For Round Strainer.
 *Collar is reversible to obtain extreme high and low strainer positions.

Fig. 2095Y..... (A) Round Top
 Fig. 2095Y..... (B) Square Top

REGULARLY FURNISHED:
 Duco Cast Iron Body with Integral Trap and 1"(25) NPT Plug and Flashing Collar and Adjustable Strainer Head as Indicated by Suffix Letter Selected.

VARIATIONS:

One to Three Side Auxiliary Inlets 1/2"(13) thru 2"(51) Tap, NPT or B.S. (Specify size, qty. and location)

Vandal Resistant -U

OPTIONAL MATERIALS:

Chrome Plated Strainer -CP (Not recommended for traffic floor)

Galvanized Body -G

High Polished Nickel Bronze -NB -HPF

Satin Polished Bronze Strainer -PB

Nickel Bronze Strainer -NB

NOTE: Dimensions Shown in Parenthesis are in Millimeters.

DRAWING NUMBER: s2095
 SIZE: A
 SCALE: NONE
 DATE: 10-22-93
 APPROVED BY: GWC
 CHECKED BY: GWC
 DRAWN BY: TWK
 FIGURE NUMBER: 2095

REV.	DATE	DESCRIPTION	BY	CKD. BY	WEIGHT POUNDS	VOLUME CUBIC FEET	FIGURE NUMBER
D	11-4-11	Rev. Reg. Furn., Opt. Mat.	TBW	CL			2095
C	10-31-97	Submittal Update	EMB	BS			
B	12-28-95	Added Dim	EMB	SB			
A	1-16-95	Revised	EMB	JCS			

WE CAN ASSUME NO RESPONSIBILITY FOR USE OF SUPERSEDED OR VOID DATA